



1715
LCR Digibridge
Instruction Manual
Form 150710/A9

©QuadTech, Inc., 2003, 2007

Domestic Sales 800-253-1230

For additional contact information please visit our website
www.quadtech.com

The material in this manual is for informational purposes only and is subject to change, without notice. QuadTech assumes no responsibility for any error or for consequential damages that may result from the misinterpretation of any procedures in this publication.

CAUTION

Voltage may be present on front and rear panel terminals. Follow all warnings in this manual when operating or servicing this instrument. Substantial levels of energy may be stored in capacitive devices tested by this unit.

Contents

Warranty	5
Specifications	7
Accessories	9
Safety Precautions	11
Condensed Operating Instructions	13
Introduction - Section 1	
1.1	Unpacking and Inspection..... 17
1.2	Product Overview 17
1.3	Controls and Indicators 18
1.3.1	Front Panel Controls and Indicators 18
1.3.2	Rear Panel Controls and Connectors 19
1.4	Installation 20
1.4.1	Dimensions 20
1.4.2	Instrument Positioning 20
1.4.3	Power Requirements 20
1.4.4	Safety Inspection..... 21
Operation - Section 2	
2.1	Terms and Conventions 23
2.2	Start-Up..... 28
2.3	SYSTEM SETUP 28
2.3.1	Calibration 28
2.3.2	Memory Manage 28
2.3.3	System Configuration 28
2.3.3.1	BEEPER 29
2.3.3.2	KEY LOCK 29
2.3.3.3	SOUND MODE 29
2.3.3.4	ALARM MODE 30
2.3.3.5	HANDLER MODE 30
2.3.3.6	GPIB ADDRESS 30
2.3.3.7	TRIGGER DELAY 31
2.3.3.8	TRIGGER EDGE 31
2.3.3.9	LINE FREQUENCY 31
2.3.3.10	BAUD RATE 32
2.3.3.11	0.25V RANGE MODE 32
2.4	MEAS DISPLAY 33
2.4.1	FREQuency 34
2.4.2	LEVEL 34
2.4.3	PARAmeter 34
2.4.4	RANGE 35
2.4.5	SPEED 36

Contents

Operation - Section 2 - Continued

2.4	MEAS DISPLAY Continued	
2.4.6	TRIGger	39
2.4.7	BINning	39
2.4.8	COMPare	40
2.5	MAIN INDEX	41
2.5.1	BINNING	41
2.5.2	COMPARE	44
2.5.3	CORRECTION	46
2.6	Connection to Device Under Test.....	50
2.7	Measurement Procedure.....	55

Interface - Section 3

3.1	RS-232 Interface	57
3.1.1	Pin Configuration	57
3.1.2	RS-232 Specifications	57
3.1.3	RS-232 Interface Commands	58
3.1.4	Sample Quick Basic Program	59
3.2	IEEE-488 Interface	60
3.2.1	Pin Configuration.....	60
3.2.2	IEEE-488 Interface Function Codes and Messages.....	62
3.2.3	IEEE-488 Interface Commands	64
3.2.4	IEEE-488 Command Format	66
3.2.5	IEEE-488 Commands - Detailed	67
3.2.6	Binning Example	76
3.2.7	Compare Example	77
3.2.8	Sample IEEE BASIC Program	78
3.3	Handler Interface	79
3.3.1	Handler Pin Assignments for Binning Operation	81
3.3.2	Handler Pin Assignments for Compare Operation	82

Service & Calibration - Section 4

4.1	General	83
4.2	Instrument Return	83
4.3	Calibration	83
4.3.1	1715 Verification Procedure	84
4.3.2	1715 Verification Data Sheet	85

Warranty



QuadTech warrants that Products are free from defects in material and workmanship and, when properly used, will perform in accordance with QuadTech's applicable published specifications. If within one (1) year after original shipment it is found not to meet this standard, it will be repaired, or at the option of QuadTech, replaced at no charge when returned to a QuadTech service facility.

Changes in the Product not approved by QuadTech shall void this warranty.

QuadTech shall not be liable for any indirect, special or consequential damages, even if notice has been given of the possibility of such damages.

This warranty is in lieu of all other warranties, expressed or implied, including, but not limited to any implied warranty or merchantability of fitness for a particular purpose.

SERVICE POLICY

QuadTech's service policy is to maintain product repair capability for a period of at least five (5) years after original shipment and to make this capability available at the then prevailing schedule of charges.

Specifications

Primary Parameters:	Ls, Lp, Cs, Cp, Rs, Rp and $ Z $ Ls, Lp: 0.01 μ H – 9.999kH Cs, Cp: 0.01pF – 99.999mF Rs, Rp: 0.1m Ω – 99.99M Ω $ Z $: 0.1m Ω – 99.99M Ω
Secondary Parameters:	D, Q, θ , Xs, Rs and Rp D: 0.0001 – 9999 Q: 0.0001 – 9999 θ : -180.00° – 180.00° Xs: 0.1m Ω – 99.99M Ω Rs, Rp: 0.1m Ω – 99.99M Ω
Measurement Accuracy:	Basic LCR: 0.2% (1kHz/1V rms) Basic DQ: \pm 0.002
Measurement Rate:	Fast: 25 measurements/second Medium: 8 measurements/second Slow: 2 measurements/second
Measurement Mode:	Continuous or Trigger (INT, EXT or Manual)
Trigger Delay:	0 – 9999ms
Ranging:	Automatic or Hold Range
Test Voltage:	0.25V and 1.0V RMS, \pm (10% + 3mV)
Test Frequency:	4 User Selectable Test Frequencies: 100Hz, 120Hz, 1kHz and 10kHz (9.6kHz) Accuracy: \pm 0.2%
Source Impedance:	25 Ω , 100 Ω , 1k Ω , 10k Ω and 100k Ω based on DUT impedance
0.25V Range Mode:	“3” uses 3 Measurement Ranges: 25 Ω , 1k Ω and 100k Ω “5” uses 5 Measurement Ranges: 25 Ω , 100 Ω , 1k Ω , 10k Ω & 100k Ω
Comparator:	Primary Nominal Primary Hi/Lo Limits (Value or %) Secondary Hi/Lo Limits (Value or %)
Bin Sorting:	Primary Nominal Primary Hi/Lo Limits (8 Bins in %) Secondary Hi/Lo Limits (Value)

Specifications (Continued)

Results Format:	<ul style="list-style-type: none"> • Value • Deviation • %Deviation • Bin Number 				
Equivalent Circuit:	Series or Parallel				
Display:	40 x 4 Character LCD display				
Indication:	Audible alarm programmable HI, LO or OFF for Pass or Fail				
Setup Storage:	1 Memory Location				
Standard Interfaces:	<ul style="list-style-type: none"> • RS232 				
Optional Interfaces:	<ul style="list-style-type: none"> • IEEE-488 • Handler 				
Connectors:	Front Connection: 4 BNC Sockets (L _{CUR} , L _{POT} , H _{POT} , H _{CUR}) GUARD: Banana Socket				
Front Panel Lockout:	Key Lock with or without setup recall, Back Lit Display: LOCK				
Mechanical:	Bench Mount Dimensions: (w x h x d):312.5 x 100.0 x 200.0 mm				
Weight:	5 kg net, 7 kg shipping				
Environmental:	Specifications: 15°C to + 35°C, 75% RH Operating: 10°C to + 40°C, 10-90% RH Storage: 0°C to + 50°C, 10-90% RH Pollution Degree 2 Installation Category II				
Power:	<ul style="list-style-type: none"> • 90-125VAC: 50Hz/60Hz, Consumption: 50VA Max • 190-250VAC: 50Hz/60Hz, Consumption: 50VA Max 				
Supplied:	<ul style="list-style-type: none"> • Instruction Manual • 1700-03 Kelvin Clip Lead Set • AC Power Cable • Calibration Certificate 				
Ordering Information:	<table border="0" style="width: 100%;"> <tr> <td style="text-align: left;"><u>Description</u></td> <td style="text-align: right;"><u>Catalog No.</u></td> </tr> <tr> <td>LCR Digibridge</td> <td style="text-align: right;">1715</td> </tr> </table>	<u>Description</u>	<u>Catalog No.</u>	LCR Digibridge	1715
<u>Description</u>	<u>Catalog No.</u>				
LCR Digibridge	1715				

Accessories

Accessories Included

Item	Quantity	QuadTech P/N
AC Power Cord	1	4200-0300
Power Line Fuse 630mA 250V SB, 5x20mm	1	520023
Power Line Fuse 315mA 250V SB, 5x20mm	1	520025
Lead Set: 4 BNC Connectors to 2 Kelvin Clips	1	1700-03
Instruction Manual	1	150710
Calibration Certificate	1	N/A

Accessories/Options Available

Item	Quantity	QuadTech P/N
Axial/Radial Component Test Fixture	1	1700-01
Axial/Radial Remote Test Fixture	1	1700-02
Lead Set: 4 BNC Connectors to 2 Kelvin Clips	1	1700-03
Lead Set: 4 BNC Connectors to 4 Banana Plugs	1	1700-04
Lead Set: 4 BNC Connectors to Chip Component Tweezers	1	1700-05
Low Voltage Chip Component Test Fixture	1	7000-07
IEEE-488 (24-pin) & Handler Interface (24-pin)	1	700171
24-pin micro-ribbon plug (for Handler)	1	4220-3024-00

NOTE:

For proper operation, the $H_{CUR}/H_{POT}/I_{CUR}/I_{POT}$ cable shields must be connected together at the DUT. This connection is already made using the 1715 recommended accessory leads. If the shields are not tied together, then at higher frequencies a resonance may occur which could cause erroneous capacitance readings.

Safety Precautions

WARNING

1. Operate the 1715 unit with its chassis connected to earth ground. The instrument is shipped with a three-prong power cord to provide this connection to ground. This power cord should only be plugged in to a receptacle that provides earth ground. Serious injury can result if the 1715 unit is not connected to earth ground.
2. Tightly connect cable(s) to the L_{CUR} terminal on the front panel. If this is not done, the DUT's casing can be charged to the high voltage test level and serious injury or electrical shock hazards could result if the DUT is touched.
3. Never touch the metal of the High Voltage probe directly. Touch only the insulated parts of the lead(s).
4. Never touch the test leads, test fixture or DUT in any manner (this includes insulation on all wires and clips) when the high voltage is applied and the red **DANGER** light is ON.
5. Before turning on the Guardian unit, make sure there is no device (DUT) or fixture connected to the test leads.
6. After each test, press the **[STOP]** (red) button for safety. This terminates the high voltage being applied to the output terminals.
7. When the red **DANGER** LED is lit or flashing, NEVER touch the device under test, the lead wires or the output terminals.
8. Before touching the test lead wires or output terminals make sure :
 - a) The red **[STOP]** button has been pressed
 - b) The red **DANGER** LED is OFF.
9. In the case of an emergency, turn OFF the POWER switch using a "hot stick" and disconnect the AC power cord from the wall. DO NOT TOUCH THE INSTRUMENT. Position the equipment so it is easy to disconnect. Always disconnect by means of the power plug or power connector.
10. If the **DANGER** LED does not go off when the **[STOP]** button is pressed, immediately stop using the tester. It is possible that the output voltage is still being delivered regardless of the TEST ON/OFF control signal.
11. When the instrument is remotely controlled, be extremely careful. The High Voltage Output is being turned On/Off with an external signal.

Safety Symbols

The product is marked with the following safety symbols.



Product will be marked with this symbol (ISO#3864) when it is necessary for the user to refer to the instruction manual in order to prevent injury or equipment damage.



Product marked with this symbol (IEC417) indicates presence of direct current.



Product will be marked with this symbol (ISO#3864) when voltages in excess of 1000V are present.

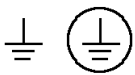

Indicates the grounding protect terminal, which is used to prevent electric shock from the leakage on chassis. The ground terminal must connect to earth before using the product.

Warning Procedure can cause hazard to human if the warning is neglected.

Caution Avoid product misuse. It may cause damage to the product itself and the DUT if the caution is neglected.

Note Important information or tips for the procedures and applications.

Warning Signal During Testing

“DANGER – HIGH VOLTAGE TEST IN PROGRESS, UNAUTHORIZED PERSONS KEEP AWAY”

Disposal

Do not dispose of electrical appliances as unsorted municipal waste, use separate collection facilities. Contact your local government for information regarding the collection systems available. If electrical appliances are disposed of in landfills or dumps, hazardous substances can leak into the groundwater and get into the food chain, damaging your health and well-being. When replacing old appliances with new one, the retailer is legally obligated to take back your old appliances for disposal.



Condensed Operating Instructions

General Information

The 1715 Digibridge is an instrument for measuring the passive component primary parameters of inductance (L), capacitance (C), resistance (R) and impedance (Z). Secondary parameters measured are dissipation factor (D), quality factor (Q), reactance (X), phase angle (θ), and resistance (R). Any two of eleven parameters can be measured simultaneously and the results formatted as value, deviation from nominal, percent deviation from nominal or by bin number. Connection to device under test is through 4-BNC terminals on the front panel.

Start-Up

The 1715 Digibridge unit can be operated from a power source between 90-125V or 190-250V AC at a power line frequency between 48 and 62Hz. Maximum power consumption is 50VA. The standard 1715 unit is shipped from QuadTech with a 630mA fuse in place for AC 90-125V operation. (A 315mA fuse is included for AC 190-250V operation). The 1715 unit is shipped with the line voltage selector set for 115V. Refer to paragraph 1.4.3 for instructions on changing the fuse or line voltage selector.

Connect the 1715 Digibridge unit AC power cord to the source of proper voltage. Operate the 1715 instrument with its chassis connected to earth ground. The 1715 instrument is shipped with a three-prong power cord to provide this connection to ground. This power cord should only be plugged into a receptacle that provides earth ground. Serious injury may result if the 1715 instrument is not connected to earth ground.

To turn the 1715 instrument ON, press the power button on the front panel. To switch the power OFF, press the button again or if measurements are to be made proceed with the Test Parameter Setup in Table COI-1. The 1715 instrument should warm up for 15 minutes prior to use.

NOTE

Please read this instruction manual in its entirety before operating this instrument. These condensed operating instructions are not a substitute for all the information provided in the remainder of this manual.

NOTE

Refer to paragraphs 2.3 through 2.5 for a full description of programming test parameters and instruction on how to store the test setup. Test parameters must be set before the 1715 instrument can be zeroed.

Condensed Operating Instructions (Continued)

There are three main menus within the 1715 Digibridge instrument software. Familiarize yourself with these menus prior to programming a test. Figure COI-1 illustrates the MEAS DISPLAY screen and lists the functions that can be accessed by pressing the [MAIN INDEX] and [SYSTEM SETUP] keys.

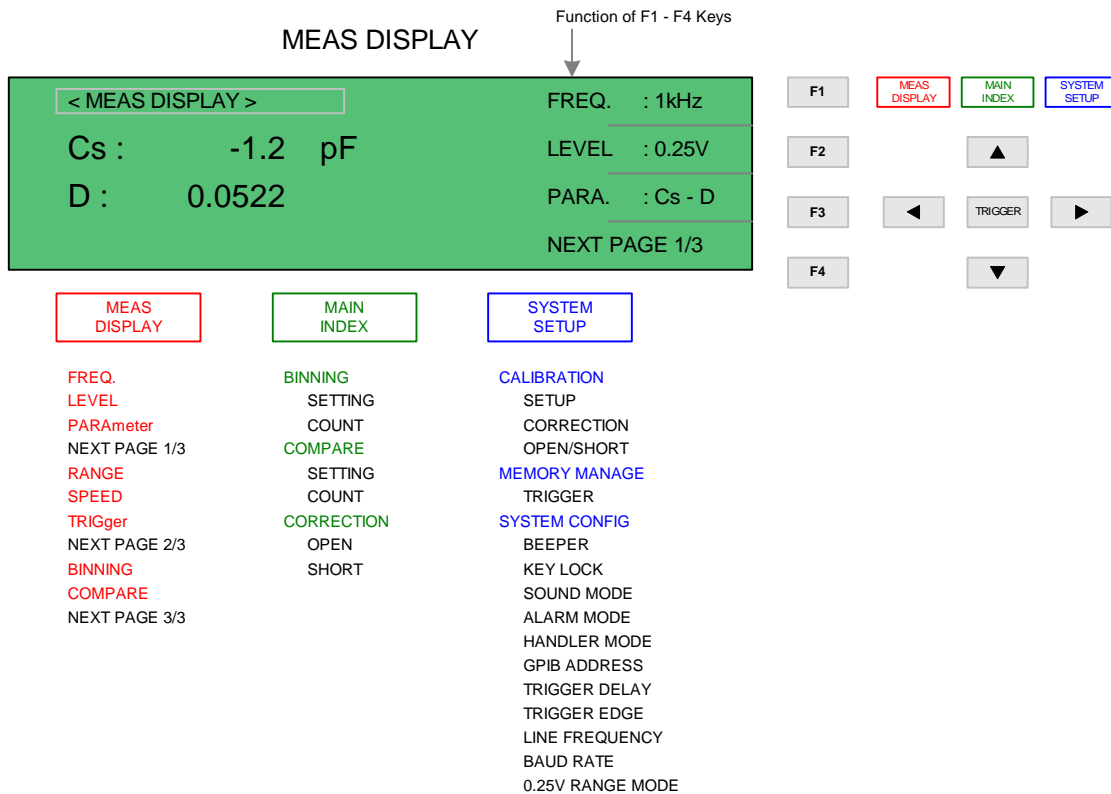

Figure COI-1: 1715 Instrument Menus

NOTE:

The function keys [F1 – F4] are used to select the parameter to change and in some menus to change the value of that selected parameter. The function of UP/DOWN depends on the menu. In some menus, the LEFT/RIGHT keys are used to select a digit by moving the underscored cursor left or right.

Condensed Operating Instructions (Continued)

1. Set Test Parameters

- Press [POWER] ON.
- Allow the instrument to warm up for 15 minutes.
- Press [MEAS DISPLAY]
- Set test parameters (frequency, voltage, parameters) using the function & arrow keys.

2. Correction (Zero)

After setting your test parameters, use the correction function of the 1715 Digibridge instrument to zero the test leads. With no device connected, connect the appropriate cable to the front panel BNC connectors. Refer to paragraph 2.6 for cable connections.

With the instrument in MEAS DISPLAY status:

1. Press [MAIN INDEX]
2. Press [CORRECTION]
3. Press [F1] = OPEN (or [F2] = SHORT) to select zero function.
4. Press [F2] = MULTI to select frequency.
5. Follow instructions on display: i.e.: “Open circuit test leads”.
6. Press [TRIGGER] button.
7. Wait while instrument gets CORRECTION value.
8. Press [F4] to exit.
9. Repeat steps 3-8 for SHORT correction.

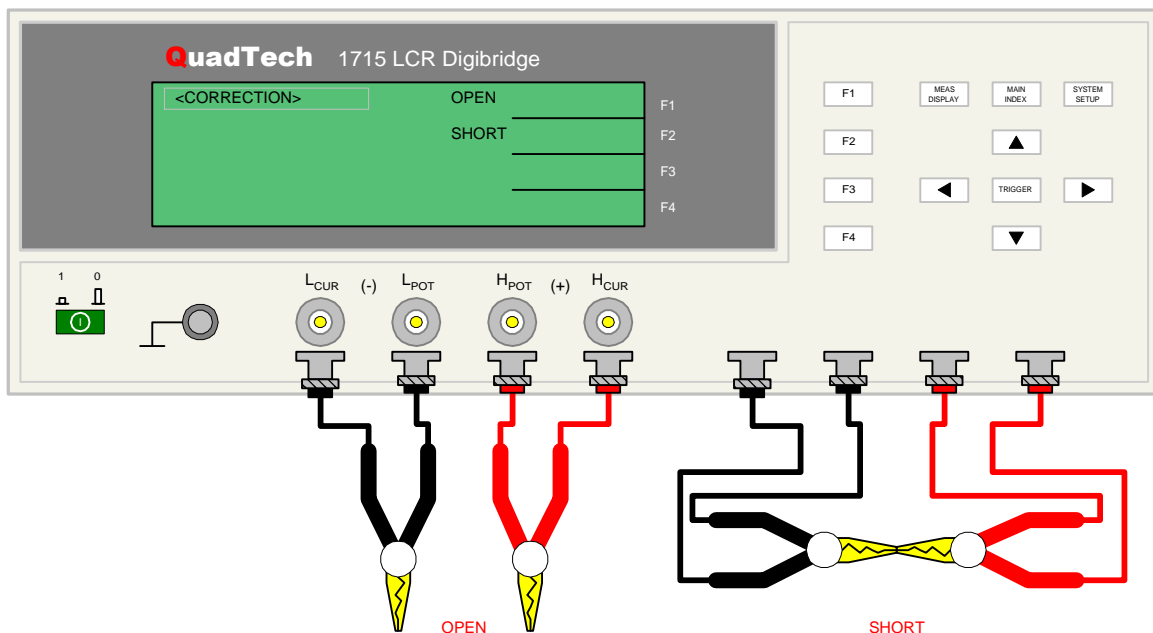
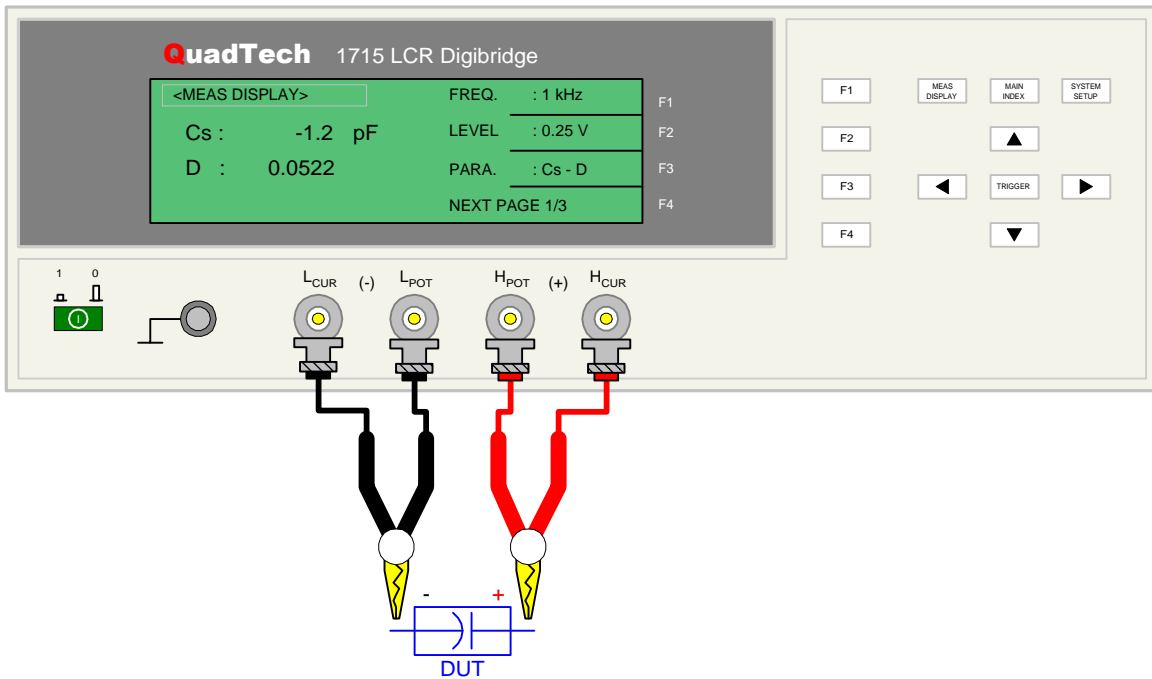

Figure COI-2: Correction OPEN & SHORT Configurations

Condensed Operating Instructions (Continued)

3. Connection to Device under Test (DUT)

Figure COI-3 illustrates the connection of the 1715 Digibridge unit to a single DUT using the 1700-03 4-BNC to Kelvin Clips cable lead set. The silver BNC connectors are connected to the front panel BNC terminals on the 1715 unit: red to H_{CUR}/H_{POT} and black to L_{CUR}/L_{POT} . The red Kelvin clip is connected to the high side of the DUT and the black Kelvin clip to the low side of the DUT.



COI-3: Connection to Device under Test

4. Make a Measurement

1. Press [MEAS DISPLAY]
2. Connect device under test (DUT) to test leads.
3. Press [TRIGGER].
4. Record measurement.

NOTE:

For proper operation, the $H_{CUR}/H_{POT}/L_{CUR}/L_{POT}$ cable shields must be connected together at the DUT. This connection is already made using the 1715 recommended accessory leads. If the shields are not tied together, then at higher frequencies a resonance may occur which could cause erroneous capacitance readings.

Section 1: Introduction

1.1 Unpacking and Inspection

Inspect the shipping carton before opening. If damaged, contact the carrier agent immediately. Inspect the 1715 Digibridge instrument for any damage. If the instrument appears damaged or fails to meet specifications notify QuadTech (refer to instruction manual front cover) or its local representative. Retain the original shipping carton and packing material for future use such as returning the instrument for recalibration or service.

1.2 Product Overview

The 1715 Digibridge instrument is a compact yet powerful LCR meter for production or laboratory testing of inductors, capacitors, resistors and other passive components. The 1715 instrument measures 11 parameters: L_s , L_p , C_s , C_p , R_s , R_p , D , Q , $|Z|$, X_s and θ and displays two simultaneously. Basic accuracy is $\pm 0.2\%$ for LCR and ± 0.002 for DQ measurements. Automatic or Hold Range can be selected. Measurement rate is also selectable (Slow, Medium or Fast) with rates up to 25 measurements per second. Measurements can be made continuously or triggered with a programmable delay time to 9999 milliseconds. The RS232 interface is standard and the IEEE-488/Handler interface is optional equipment on the 1715 instrument. Zero the effects of stray admittance/residual impedance in the test leads with the open/short correction function. The 1715 unit automatically selects the instrument source impedance as 25Ω , 100Ω , $1k\Omega$, $10k\Omega$ or $100k\Omega$ based on the impedance of the device under test. Four test frequencies are selectable: 100Hz, 120Hz, 1kHz and 10kHz (9.6kHz). The 1715 instrument is equipped with 8 Pass/Fail bins. Test results can be formatted as nominal value, deviation from nominal value or %deviation from nominal value. Bin number or Pass/Fail can be displayed as well. Connection to the device under test is through 4 BNC terminals on the front panel.

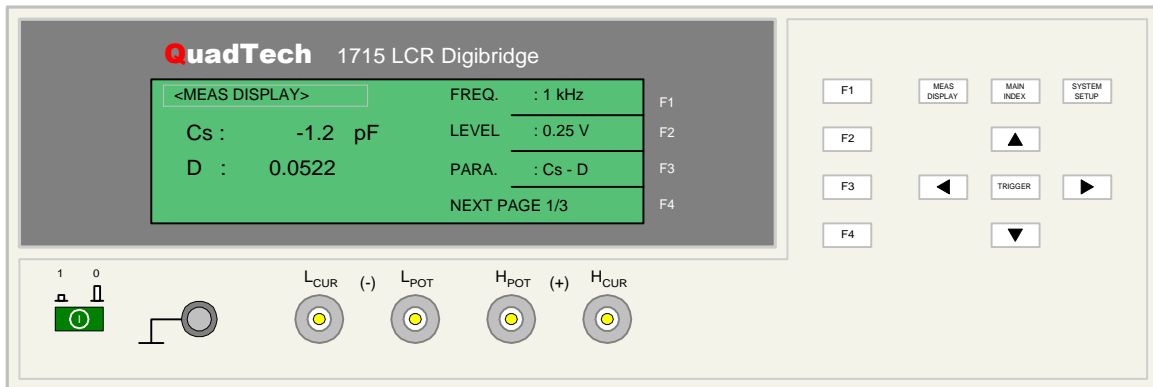

Figure 1-1: 1715 LCR Digibridge

1.3 Controls and Indicators

1.3.1 Front Panel Controls and Indicators

Figure 1-2 illustrates the controls and indicators on the front panel of the 1715 Digibridge instrument. Table 1-1 identifies them with description and function.

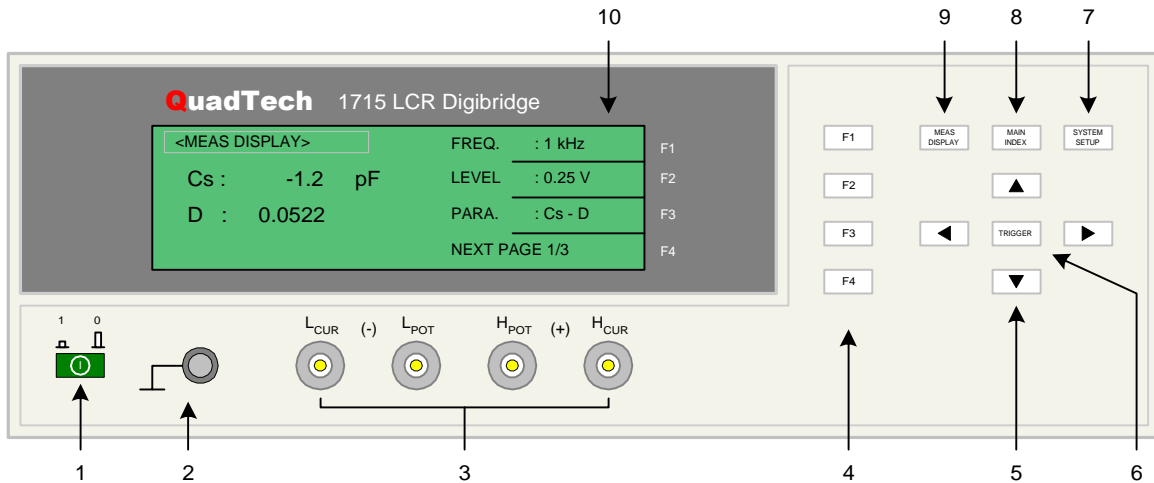

Figure 1-2: 1715 Front Panel Controls & Indicators

Table 1-1: 1715 Front Panel Controls & Indicators

Reference # Figure 1-2	Name	Type	Function
1		Green Push Button	Apply AC POWER: 1=ON, 0=OFF
2		Silver Banana Jack	Chassis ground connection
3	L _{CUR} L _{POT} H _{POT} H _{CUR}	4 silver BNC terminals	Current Drive Terminal, Low (-) Voltage Sense Terminal, Low (-) Voltage Sense Terminal, High (+) Current Drive Terminal, High (+)
4	F1, F2, F3 and F4	4 gray push buttons	Select Instrument Functions Keys perform different functions under different menus. Right side of display shows corresponding key function.
5	◀, ▼, ▶, ▲	4 gray push buttons	Move backlit box around display to choose parameter Change parameter value (increase/decrease)
6	TRIGGER	Gray push button	Initiate measurement
7	SYSTEM SETUP	Gray push button	View, Select or Change System Parameters: Calibration, Memory Manage & System Config (Beeper, Key Lock, Sound, Alarm, Handler, GPIB Address, Trigger Delay, Trigger Edge & Line Frequency)
8	MAIN INDEX	Gray push button	View, Select or Change Setup & Result Parameters: Binning, Compare, & Correction
9	MEAS DISPLAY	Gray push button	View, Select or Change Measurement Parameters: Frequency, Voltage, Parameter (Pri/Sec), Range, Speed, Trigger, Binning and Compare
10		40 x 4 Character LCD display	Show measurement results as value, deviation, %deviation or bin number. Show programming instructions

1.3.2 Rear Panel Controls and Connectors

Figure 1-3 illustrates the controls and connectors on the rear panel of the 1715 Digibridge instrument. Table 1-2 identifies them with description and function.

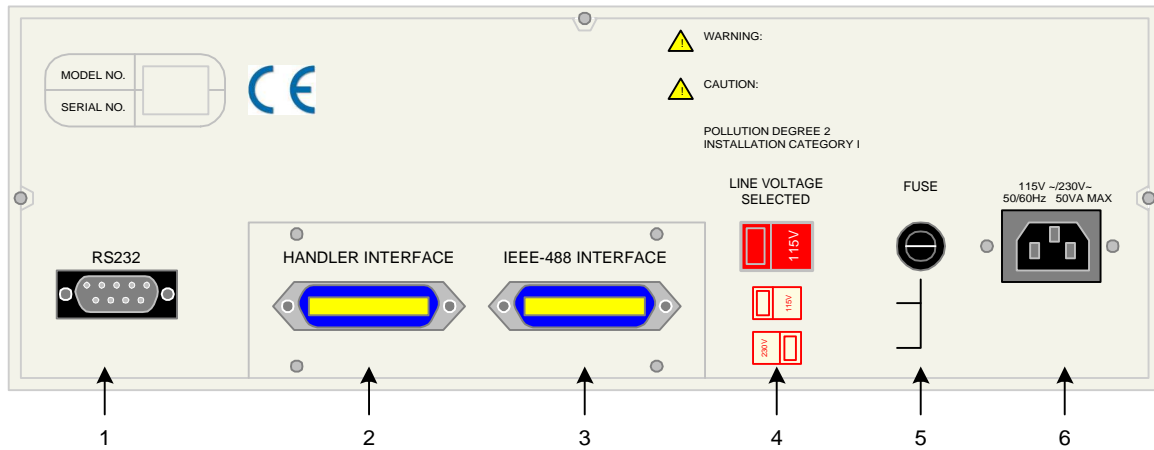

Figure 1-3: Rear Panel 1715 Instrument

Table 1-2: 1715 Rear Panel Controls & Connectors

Reference # Figure 1-3	Name	Type	Function
1	RS 232 INTERFACE	Silver /Black 9-pin connector	RS 232 interface for remote operation
2	HANDLER INTERFACE	Blue 24-pin connector	Handler Interface connector for remote operation
3	IEEE-488 INTERFACE	Blue 24-pin connector	IEEE-488 Interface connector for data transfer
4	LINE VOLTAGE SELECTED	2 Red 2-position Slide Switches	Select Voltage Level corresponding to AC Source 90V – 125V: T630mA 250V fuse 190V – 250V: T 315mA 250V fuse
5	FUSE	Black Screw cap fuse holder	Short circuit protection T 630mA 250V fuse for 115V operation T 315mA 250V fuse for 230V operation
6	AC Line Input	Black 3-wire inlet module	Connection to AC power source

1.4 Installation

1.4.1 Dimensions

The 1715 Digibridge unit is supplied in a bench configuration, i.e., in a cabinet with resilient feet for placement on a table. The 1715 instrument can be tilted up for convenient operator viewing by extending the front feet out.

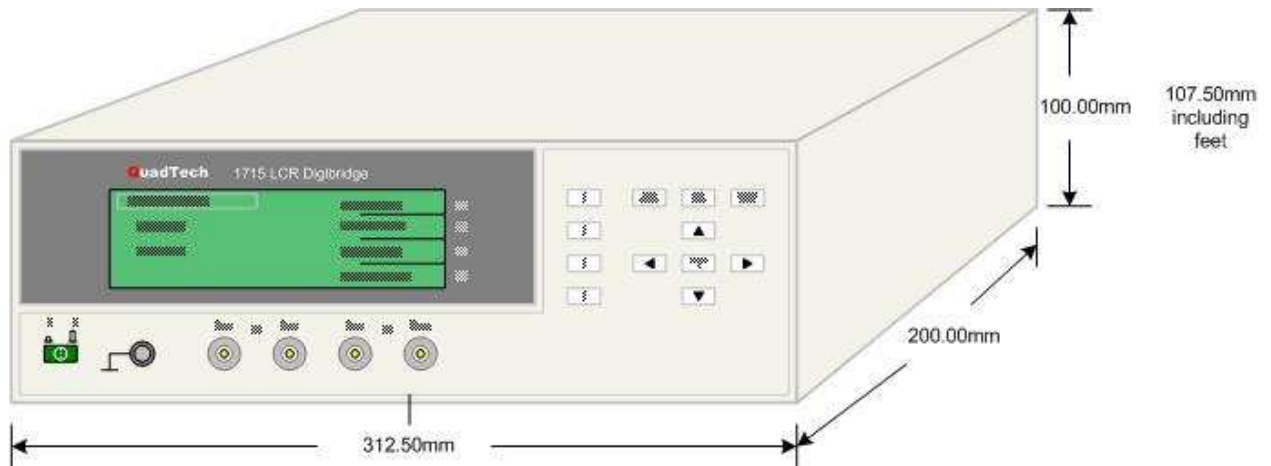

Figure 1-4: 1715 Instrument Dimensions

1.4.2 Instrument Positioning

The 1715 instrument contains one (1) LCD display for direct readout of measured parameters. The optimum angle for viewing is slightly down and about 10 degrees either side of center. For bench operation the front flip feet should always be used to angle the instrument up. In bench or rack mount applications the instrument should be positioned with consideration for ample air flow around the rear panel fan ventilation hole. An open space of at least 3 inches (75mm) is recommended behind the rear panel. Testing should be performed on a non-conductive surface. An ESD mat is not a recommended test platform.

1.4.3 Power Requirements

The 1715 can be operated from a power source of 90 to 125V AC or 190 to 250V AC. Power connection is via the rear panel through a standard receptacle. Before connecting the 3-wire power cord between the unit and AC power source, make sure the voltage selection switches on the rear panel (Figure 1-5) are in accordance with the power source being used. For a 90-125V source, use a 630mA 250V fuse. For a 190-250V source, use a 315mA 250V fuse. Always use an outlet that has a properly connected protection ground.

CAUTION

Make sure the unit has been disconnected from its AC power source for at least five minutes before proceeding.

Procedure for Changing a 1715 Instrument Fuse

Unscrew the fuse cap on the rear panel of the 1715 and pull fuse holder outward.

Once the fuse holder has been removed from the instrument snap the fuse from the holder and replace. Make sure the new fuse is of the proper rating.

Install the fuse back into the cap holder by pushing in until it locks securely in place.

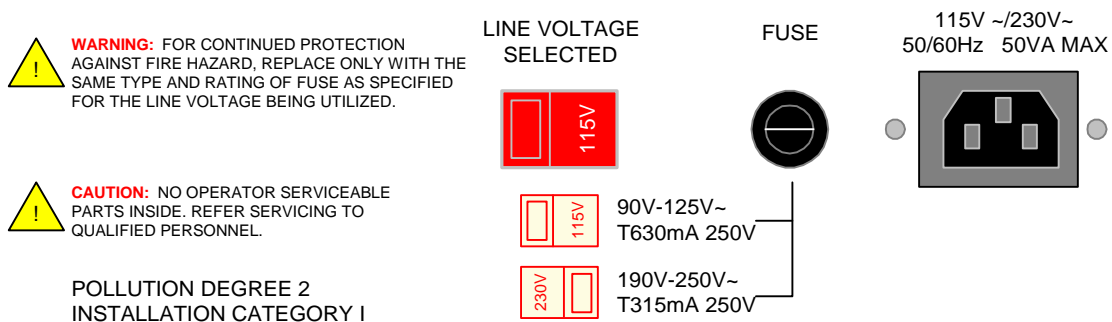

Figure 1-5: Close-Up of 1715 Rear Panel

1.4.4 Safety Inspection

Before operating the instrument inspect the fuse holder on the rear of the 1715 instrument to ensure that the properly rated fuse is in place, otherwise damage to the unit is possible. Make sure that the voltage selector switches are set in accordance with the power source in use. Refer to paragraph 1.4.3 and Figure 1-5.

The 1715 instrument is shipped with a standard U.S. power cord, QuadTech P/N 4200-0300 (with Belden SPH-386 socket or equivalent, and a 3-wire plug conforming to IEC 320). Make sure the instrument is only used with these cables (or other approved international cord set) to ensure that the instrument is provided with connection to protective earth ground.

The surrounding environment should be free from excessive dust to prevent contamination of electronic circuits. The surrounding environment should also be free from excessive vibration. Do not expose the 1715 instrument to direct sunlight, extreme temperature or humidity variations, or corrosive chemicals.

Section 2: Operation

2.1 Terms and Conventions

Table 2-1: Measurement Unit Prefixes

<u>Multiple</u>	<u>Scientific</u>	<u>Engineering</u>	<u>Symbol</u>
1000000000000000	10 ¹⁵	Peta	P
1000000000000	10 ¹²	Tera	T
1000000000	10 ⁹	Giga	G
1000000	10 ⁶	Mega	M
1000	10 ³	Kilo	k
.001	10 ⁻³	milli	m
.000001	10 ⁻⁶	micro	μ
.000000001	10 ⁻⁹	nano	n
.000000000001	10 ⁻¹²	pico	p
.000000000000001	10 ⁻¹⁵	femto	f

Accuracy: The difference between the measured value or reading and the true or accepted value. The accuracy of an LCR meter is typically given as a ± percentage of the measured value for primary parameters and ± an absolute value for secondary value. For example: ±0.05% for L, C & R and ±0.0005 for Df.

Basic Accuracy: Basic accuracy is specified at optimum test signal, frequencies, highest accuracy setting or slowest measurement speed and impedance of the DUT. As a general rule this means 1VAC RMS signal level, 1kHz frequency, high accuracy which equates to 1 measurement/second, and a DUT impedance between 10Ω and 100kΩ.

Binning: Procedure for sorting components into bins using sequential limits or nested limits.

Capacitor: Abbreviated C (as in LCR). A capacitor is passive component comprised of two conductors separated by a dielectric. A capacitor stores charge blocks DC flow and allows AC flow based on frequency and capacitor design.

Capacitance: The measure of the ratio of charge on either plate of a capacitor to the potential difference (voltage) across the plates. Unit of measure is the Farad (F).

Capacitive Reactance: A measurement of the actual AC resistance of a capacitor. How effective a capacitor allows AC to flow depends upon its capacitance and the frequency used. $X_C = 1 / 2\pi fC$.

Compare: Procedure for sorting components by comparing the measured value against a known standard.

Current:

AC: Alternating Current. AC is an electrical current that has one polarity during part of the cycle and the opposing polarity during the other part of the cycle. Residential electricity is AC.

DC: Direct Current. Non-reversing polarity. The movement of charge is in one direction. Used to describe both current and voltage. Batteries supply direct current (DC).

Dielectric: A material which is an electrical insulator or in which an electric field can be sustained with a minimum dissipation of power.

Dielectric Constant: Abbreviated K, relative dielectric constant. The dielectric constant of a material is the ratio of the capacitance of a capacitor filled with a given dielectric to that same capacitor having only a vacuum as a dielectric.

Discharge: The act of draining off an electrical charge to ground. Devices that retain charge should be discharged after an IR test or DC hipot test.

DUT: Device Under Test. (i.e. the product being tested).

Equivalent Circuit:

The configuration of the device under test. Is it a series or parallel equivalent circuit?

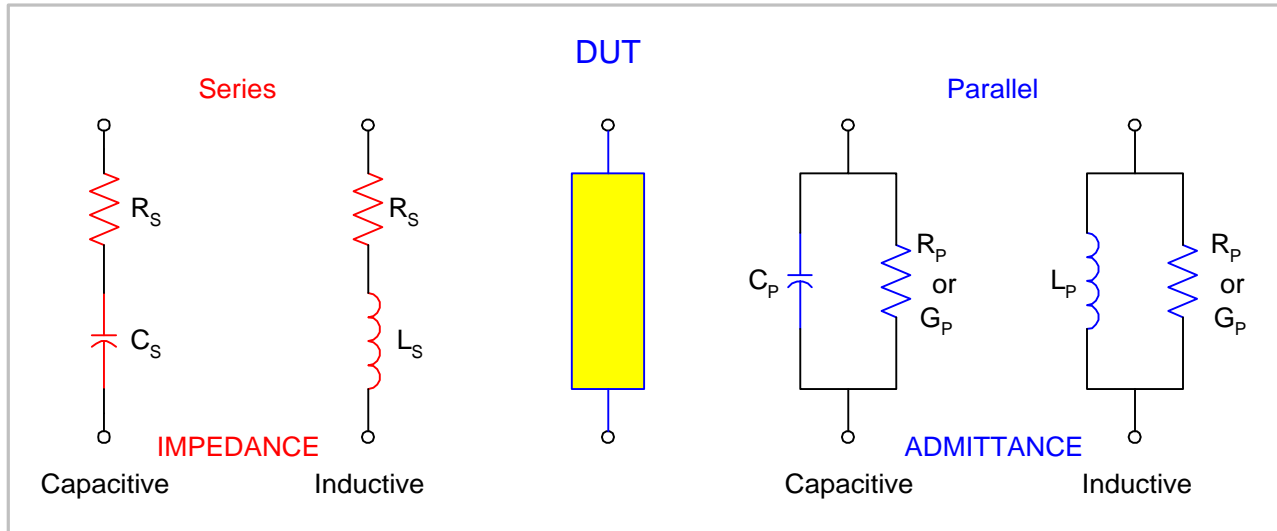

Frequency:

The rate at which current or voltage reverses polarity and then back again completing a full cycle, measured in Hertz (Hz) or cycles/second. AC Line Frequency = 50/60 Hz.

Ground:

The base reference from which voltages are measured, nominally the same potential as the earth. Ground is also the side of a circuit that is at the same potential as the base reference.

Impedance:

The AC resistance of the DUT. Impedance (Z) is a vector summation of resistance R and reactance X .

For capacitors reactance is defined as $X_C = 1/j\omega C$

For inductors reactance is defined as $X_L = j\omega L$

For resistors resistance is defined as R

Impedance is defined as $Z = \sqrt{X^2 + R^2}$

Inductor:

Abbreviated L (as in LCR). An inductor is a coil of wire. It is used to create electromagnetic induction in a circuit.

Inductance:

The property of a coil to oppose any change in current through it. If the turns (coils) of the wire are stretched out, the field intensity will be less and the inductance will be less. Unit of measure is the Henry (H).

Inductive Reactance:

A measure of how much the counter electro-magnetic force (emf) of the coil will oppose current variation through the coil. The amount of reactance is directly proportional to the current variation: $X_L = 2\pi fL$.

Interface:

Handler:	Device for remote control of test instrument in component handling operations.
IEEE-488:	General Purpose Interface Bus (GPIB). GPIB is an industry standard definition of a Parallel bus connection for the purpose of communicating data between devices.
RS232:	An industry standard definition for a Serial line communication link or port.
Scanner:	An electronic device designed to switch or matrix signals.
Level:	The test signal level is the programmed RMS voltage of the generator in an LCR meter. The actual test voltage across the DUT is always less than the programmed level. Refer to VM/IM feature to view actual signal across DUT.

Limits:

High Limit:	The high limit is the upper value for a test to be considered a pass. If the measured value is higher than the high limit the test is considered a fail.
Low Limit:	The low limit is the lower value for a test to be considered a pass. If the measured value is lower than the low limit the test is considered a fail.
Parameter:	Electrical property being tested. The primary parameter (L, C, R) is the first property characterized of the device under test. The secondary parameter (D, Q, θ) is the second property characterized of the device under test.
Permittivity:	Abbreviated ϵ . The dielectric constant multiplied by the dielectric constant of empty space (ϵ_0), where the permittivity of empty space (ϵ_0) is a constant in Coulomb's Law, equal to a value of 1 in centimeter-gram-second units and to 8.854×10^{-12} farads/meter in rationalized meter-kilogram-second units.
Range:	The resistance ranges the instrument uses for reference in making the measurement.

Repeatability: The difference between successive measurements with no changes in the test setup or test conditions.

Reproducibility: Similar to repeatability but adds the element of what could be expected under real life conditions. Reproducibility would take into account the variability in thing like fixturing where the DUT being tested is removed from the fixture and then inserted again.

Resolution: The smallest value that can be shown on the display in a digital instrument. LCR meters typically specify a measurement range that is the largest and smallest value that can be shown on the display.

Source Impedance: A constant source resistance of the measuring instrument used to level the voltage across the DUT to a constant voltage.

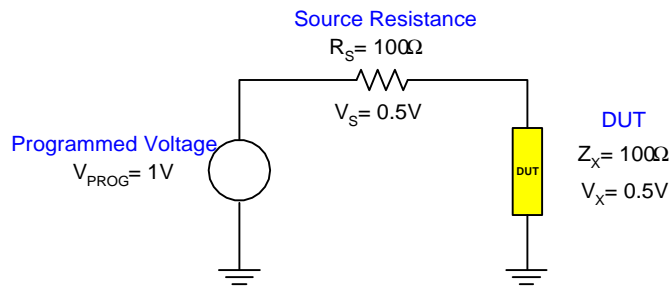

Speed: The rate at which the instrument makes a measurement in measurements per second. Speed is inversely proportional to accuracy.

Trigger: The device for initiating the test (applying the voltage or current).

External: The test is initiated via an external source such as a computer with an IEEE-488 or Handler interface. One measurement is made each time the external trigger is asserted on the handler.

Internal: The instrument continuously makes measurements.

Manual: The operator initiates the test by pressing the [START] button. One measurement is made each time the trigger is pressed.

2.2 Startup

Check to make sure the red Line Voltage Selector switch on the rear panel agrees with the power source available. Depending on the power source the switch position should be in the up or down position as shown in Figure 1-5 (Close-Up of 1715 Rear Panel).

Connect the instrument power cord to the source of proper voltage. **The instrument is to be used only with three-wire grounded outlets.**

Power is applied to the 1715 instrument by pressing the green power switch on the front panel to the ON (1 position). The 1715 unit should warm up for a period of at least 15 minutes prior to measurements being made.

2.3 SYSTEM SETUP

The SYSTEM SETUP menu contains three functions: Calibration, Memory Management and System Configuration. Press the [SYSTEM SETUP] button to access these functions.

2.3.1 Calibration

For QuadTech service personnel only. Calibration of the 1715 instrument is required during initial manufacture only. Verification is recommended on an annual basis.

2.3.2 Memory Management

For QuadTech service personnel only.

2.3.3 System Configuration

Prior to programming a test or measuring a device, set up the system controls of the 1715 instrument. To access the system controls, press [SYSTEM SETUP] then press [SYSTEM CONFIG]. Table 2-2 lists the contents of SYSTEM CONFIG.

Table 2-2: SYSTEM CONFIG

Parameter	Function	Range
BEEPER	Set beeper loudness	OFF, LOW or HIGH
KEY LOCK	Lock out front panel programming	OFF/ON
SOUND MODE	Set when the buzzer will sound	PASS/FAIL
ALARM MODE	Set type of alarm signal	PULSE/CONTINUOUS
HANDLER MODE	Set handler interface mode	CLEAR/HOLD
GPIB ADDRESS	Set interface address	00 – 30
TRIGGER DELAY	Set external trigger time	0000 – 9999 ms
TRIGGER EDGE	Set trigger mode	FALLING/RISING
LINE FREQUENCY	Set power line frequency	50Hz/60Hz
BAUD RATE	Set baud rate	2400/4800/9600/19200/38400
0.25V RANGE MODE	Set measurement range for 0.25V	3 or 5

2.3.3.1 BEEPER

The loudness of the beeper or audible alarm can be set to OFF, LOW or HIGH. The instrument default setting is LOW. To change the beeper loudness press [SYSTEM SETUP], [SYSTEM CONFIG] and the down arrow [↓] until the box next to BEEPER is highlighted, then press [F1] = OFF, [F2] = LOW or [F3] = HIGH.

Go to KEY LOCK ▼

< SYSTEM CONFIG >		OFF
BEEPER:	LOW	LOW
KEY LOCK:	OFF	HIGH
SOUND MODE:	FAIL	

F1 Turn Beeper OFF
 F2 Set Beeper Volume to LOW
 F3 Set Beeper Volume to HIGH
 Default: LOW

2.3.3.2 KEY LOCK

To lock out the front panel operations with the exception of the [TRIGGER] key, set the key lock function to ON. Press [SYSTEM SETUP], [SYSTEM CONFIG], [↓] until OFF is highlighted next to KEY LOCK, then press [F1] = ON. The backlit LOCK block will appear on the measure display. To turn the key lock function OFF: press [F1], [F4] and then [SYSTEM SETUP]. Key lock can be set ON or OFF. The instrument default setting is OFF.

Go to SOUND Mode ▼

< SYSTEM CONFIG >		OFF
BEEPER:	LOW	ON
KEY LOCK:	OFF	
SOUND MODE:	FAIL	

F1 Front Panel keys are Operational
 F2 Front Panel keys are Non-Operational
 Default: OFF

2.3.3.3 SOUND Mode

The audible alarm can be set to sound on PASS or to sound on FAIL under high or low limit judgment in the measure display. The instrument default setting is FAIL. To change the sound mode press [SYSTEM SETUP], [SYSTEM CONFIG] and the down arrow [↓] until the box next to SOUND MODE is highlighted, then press [F1] = PASS for the alarm to sound on a pass result or [F2] = FAIL for the alarm to sound on a fail result.

Go to ALARM Mode ▼

< SYSTEM CONFIG >		FAIL
BEEPER:	LOW	PASS
KEY LOCK:	OFF	
SOUND MODE:	FAIL	

F1 Select alarm to sound on FAIL
 F2 Select alarm to sound on PASS
 Default: FAIL

2.3.3.4 ALARM Mode

The type of audible alarm can be set to PULSE or CONTINUOUS during judgment in the measure display. The instrument default setting is PULSE. To change the alarm mode press [SYSTEM SETUP], [SYSTEM CONFIG] and the down arrow [↓] until the box next to ALARM MODE is highlighted, then press [F1] = PULSE for the alarm to sound in a pulse tone or [F2] = CONTINUOUS for the alarm to sound continuously.

Next Page
Go to HANDLER Mode ▼

< SYSTEM CONFIG >	PULSE
ALARM MODE: PULSE <input type="checkbox"/>	CONTINUOUS
HANDLER MODE: CLEAR	
GPIB ADDRESS: 17	

F1 Select alarm to sound as a PULSE
F2 Select alarm to sound CONTINUOUSLY
Default: PULSE

2.3.3.5 HANDLER Mode

The handler interface mode can be set to CLEAR or HOLD. The instrument default setting is CLEAR. When set to CLEAR, the handler interface will clear the last test result prior to each subsequent measurement. When set to HOLD, the handler interface will hold the last test result until the next measurement is made and displayed. To change the handler mode press [SYSTEM SETUP], [SYSTEM CONFIG] and the down arrow [↓] until the box next to HANDLER MODE is highlighted, then press [F1] = CLEAR or [F2] = HOLD.

Go to GPIB ADDRESS ▼

< SYSTEM CONFIG >	CLEAR
ALARM MODE: PULSE	HOLD
HANDLER MODE: CLEAR <input checked="" type="checkbox"/>	
GPIB ADDRESS: 17	

F1 Select handler to CLEAR result
F2 Select handler to HOLD result
Default: CLEAR

2.3.3.6 GPIB Address Code

The IEEE-488 interface address can be programmed from 00 to 30. The instrument default setting is 17. To change the GPIB ADDRESS press [SYSTEM SETUP], [SYSTEM CONFIG] and the down arrow [↓] until the box next to GPIB ADDRESS is highlighted, then press [F1] = DIGIT UP to increase the address, or [F2] = DIGIT DOWN to decrease the address.

Go to Trigger Delay ▼

< SYSTEM CONFIG >	INCREASE
ALARM MODE: PULSE	DECREASE
HANDLER MODE: CLEAR	DIGIT
GPIB ADDRESS: <u>17</u>	

F1 Increase Address Digit: 0 - 9
F2 Decrease Address Digit: 9 - 0
F3 Move underscore cursor left and right
Range: 00 - 30, Default: 17

2.3.3.7 TRIGGER Delay

The trigger delay is the amount of time between the activation of a trigger (via IEEE, Handler or front panel) and the 1715 making the measurement. The delay time can be programmed from 0000 to 9999 milliseconds. The instrument default value is 0000 milliseconds. To change the TRIGGER DELAY press [SYSTEM SETUP], [SYSTEM CONFIG] and the down arrow [↓] until the box next to TRIGGER DELAY is highlighted, then press [F1] = DIGIT UP to increase the delay time, [F2] = DIGIT DOWN to decrease the delay time or [F3] = DIGIT to move over a decimal place.

Next Page

Go to Trigger Edge ▼

< SYSTEM CONFIG >	INCREASE
TRIGGER DELAY: 0000 mS	DECREASE
TRIGGER EDGE: FALLING	DIGIT
LINE FREQUENCY: 60 Hz	

F1 Increase Delay Time digit: 0 - 9
 F2 Decrease Delay Time digit: 9 - 0
 F3 Move underscore cursor left and right
 Range: 0 - 9999mS, Default: 0 milliseconds

2.3.3.8 TRIGGER Edge

Select on which edge the measurement is triggered: FALLING or RISING. The instrument default setting is FALLING. To change the TRIGGER EDGE press [SYSTEM SETUP], [SYSTEM CONFIG] and the down arrow [↓] until the box next to TRIGGER EDGE is highlighted, then press [F1] = FALLING or [F2] = RISING.

Go to Line Frequency ▼

< SYSTEM CONFIG >	FALLING
TRIGGER DELAY: 0 mS	RISING
TRIGGER EDGE: FALLING <input type="checkbox"/>	
LINE FREQUENCY: 60 Hz	

F1 Select Trigger Edge = FALLING
 F2 Select Trigger Edge = RISING
 Default: FALLING

2.3.3.9 Line Frequency

Select the power line frequency: 50Hz or 60Hz. The instrument default setting is 60Hz. To change the LINE FREQUENCY press [SYSTEM SETUP], [SYSTEM CONFIG] and the down arrow [↓] until the box next to LINE FREQUENCY is highlighted, then press [F1] = 50Hz or [F2] = 60Hz.

Go to Baud Rate ▼

< SYSTEM CONFIG >	50 Hz
TRIGGER DELAY: 0 mS	60 Hz
TRIGGER EDGE: FALLING	
LINE FREQUENCY: 60 Hz <input type="checkbox"/>	

F1 Select power line frequency = 50Hz
 F2 Select power line frequency = 60Hz
 Default: 60Hz

2.3.3.10 Baud Rate

The baud rate is the amount of bits per second transferred via the RS232 interface. The baud rate can be programmed as: 2400, 4800, 9600, 19200 or 38400 bps. The instrument default value is 19200 bps. To change the BAUD RATE press [SYSTEM SETUP], [SYSTEM CONFIG] and the down arrow [↓] until the box next to BAUD RATE is highlighted, then press [F1] = INCREASE to increase the baud rate or [F2] = DECREASE to decrease the baud rate.

Next Page

To 0.25V RANGE MODE ▼

< SYSTEM CONFIG >

BAUD RATE: 19200 INCREASE

0.25V RANGE MODE: 5 DECREASE

F1 Increase Baud Rate

F2 Decrease Baud Rate

Default: 19200

Range: 2400, 4800, 9600, 19200 & 38400

2.3.3.11 0.25V Range Mode

The 0.25V Range Mode tells the 1715 instrument which measurement ranges to use in a 0.25V test. This mode should be set to “5” meaning the 1715 instrument uses all 5 measurement ranges: 25Ω, 100Ω, 1kΩ, 10kΩ and 100kΩ. If set to “3” then the 1715 instrument uses only the low, mid and high measurement ranges: 25Ω, 1kΩ and 100kΩ. The “3” setting is used to make the 1715 compatible with the older 1710 meter.

The 0.25V range mode can be set to: 3 or 5 and the instrument default value is 5. To change the 0.25V RANGE MODE press [SYSTEM SETUP], [SYSTEM CONFIG] and the down arrow [↓] until the box next to 0.25V RANGE MODE is highlighted, then press [F1] = INCREASE to increase the baud rate or [F2] = DECREASE to decrease the # of measurement ranges.

Go to GPIB ADDRESS ▼

< SYSTEM CONFIG >

BAUD RATE: 19200 INCREASE

0.25V RANGE MODE: 5 DECREASE

F1 Increase Range Mode

F2 Decrease Range Mode

Default: 5

3: 25Ω, 1kΩ and 100kΩ

5: 25Ω, 100Ω, 1kΩ, 10kΩ and 100kΩ

2.4 MEAS DISPLAY

The 1715 instrument's stand-by display is the MEAS DISPLAY. After power has been applied to the instrument and it cycles quickly through the information screen, the instrument reverts to the MEAS DISPLAY. To view the instrument information screen as illustrated in Figure 2.1, press [SYSTEM SETUP] then [←].

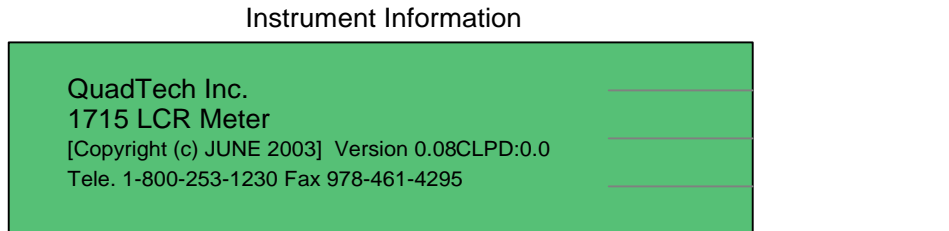

Figure 2.1: Instrument Information Screen

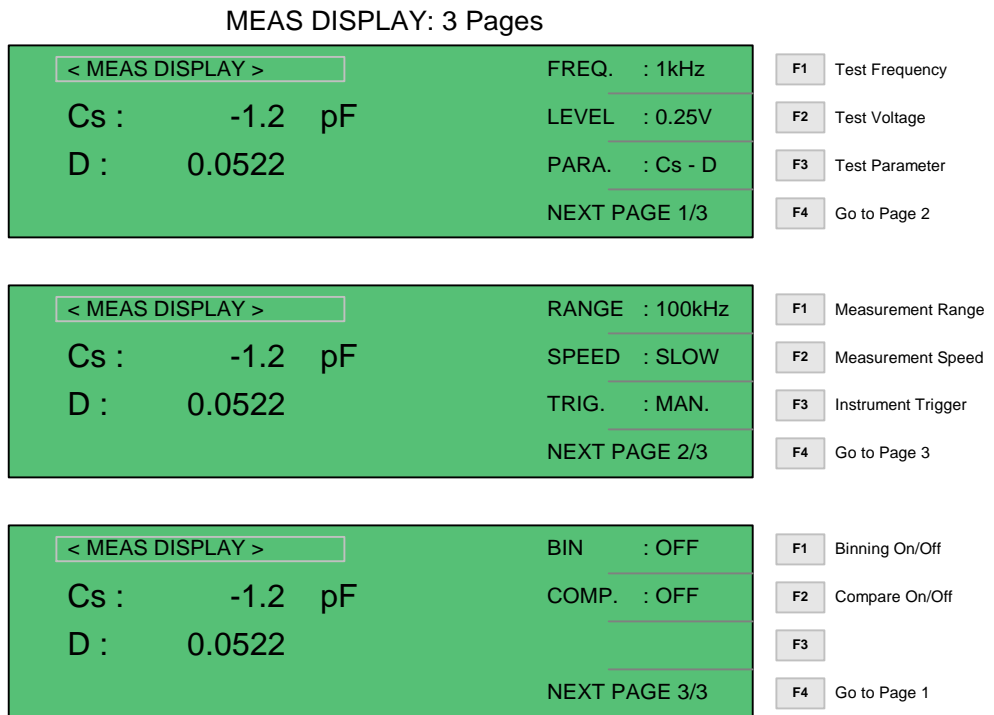

Figure 2.2: MEAS DISPLAY

Figure 2.2 illustrates the three pages of parameters that can be programmed within the MEAS DISPLAY. The binning and comparison functions are enabled/disabled in MEAS DISPLAY and programmed in MAIN INDEX Paragraphs 2.4.1 through 2.4.9 explain each parameter in detail.

2.4.1 FREQuency

The 1715 instrument provides four test frequencies in the 100Hz to 10kHz range including 100Hz, 120Hz, 1kHz and 10kHz (9.6kHz). In MEAS DISPLAY, press [F1] so that the highlighted cursor is to the right of 1.0 kHz. Use the up arrow [\uparrow] key to increase the frequency value or use the down arrow [\downarrow] key to decrease the frequency value. The instrument default setting is 1.0kHz.

The screenshot shows the MEAS DISPLAY screen with the following information:

- Header: < MEAS DISPLAY >
- Primary parameter: Cs : -1.2 pF
- Secondary parameter: D : 0.0522
- FREQ. : 1kHz
- LEVEL : 0.25V
- PARA. : Cs - D
- Footer: NEXT PAGE 1/3

To the right is the F1 control panel:

- F1 Select test frequency: 100Hz, 120Hz, 1kHz, 10kHz
- Up arrow: 10kHz
- Down arrow: 120Hz, 100Hz

2.4.2 LEVEL

The test voltage can be selected as: 0.25V or 1.00V RMS. In MEAS DISPLAY press [F2] so that the 1.00 V box is highlighted. Press [F2] to toggle between values. The instrument default setting is 1.00V.

The screenshot shows the MEAS DISPLAY screen with the following information:

- Header: < MEAS DISPLAY >
- Primary parameter: Cs : -1.2 pF
- Secondary parameter: D : 0.0522
- FREQ. : 1kHz
- LEVEL : 0.25V
- PARA. : Cs - D
- Footer: NEXT PAGE 1/3

To the right is the F2 control panel:

- F2 Select test voltage: 0.25V 1.00V
- Up arrow: 1.00V
- Down arrow: 0.25V

2.4.3 PARAMeter

The 1715 instrument can measure 11 different LCR parameters and display two (primary and secondary) simultaneously. In MEAS DISPLAY press [F3] so that the CsD box is highlighted. Use the down arrow [\downarrow] key to change/select the primary parameter. Use the right arrow [\Rightarrow] key to move the highlighted box to s and use the [\uparrow] key to select the equivalent circuit equal to series or parallel. Use the right arrow [\Rightarrow] key to move the highlighted box to D and use the down arrow [\downarrow] key to select the secondary parameter. The instrument default setting is CsD.

The screenshot shows the MEAS DISPLAY screen with the following information:

- Header: < MEAS DISPLAY >
- Primary parameter: Cs : -1.2 pF
- Secondary parameter: D : 0.0522
- FREQ. : 1kHz
- LEVEL : 0.25V
- PARA. : Cs - D
- Footer: NEXT PAGE 1/3

To the right is the F3 control panel:

- F3 Select Primary & Secondary parameter
- Down arrow: Select Primary parameter (C, R, Z, L)
- Right arrow: Move highlighted box right (Select Series or Parallel)
- Right arrow: Move highlighted box right (Select Secondary parameter (D, θ , X, Q, R))

Annotations below the screen:

- Primary Measurement Parameter: points to Cs
- Equivalent Circuit: points to -
- Secondary Measurement Parameter: points to D

The programming of parameter may at first seem a little confusing but remember the highlighted box is what is selected then pressing the down arrow [↓] key will toggle through the choices. Use the right arrow [⇒] key to move the highlighted box and select the next parameter then press the down arrow [↓] key to toggle through the choices. Table 2-3 lists the primary and secondary parameters in common pair configuration that are measurable by the 1715 instrument.

Table 2-3: 1715 Measurement Parameters

Primary		Secondary	
Cs	Capacitance	D/Rs/θ/Xs/Q	Dissipation Factor
Cp	Capacitance	D/Rp/Q	Dissipation Factor
Rs	Resistance	Xs/Q/D/Rs/θ	Series Reactance
Rp	Resistance	Q	Quality Factor
Zs	Impedance	θ/Xs/Q/D/Rs	Phase Angle
Ls	Inductance	Q/Rs/D/θ/Xs	Quality Factor
Lp	Inductance	Q/Rp/D	Quality Factor

2.4.4 RANGE

The 1715 instrument's measurement range can be selected as AUTO or HOLD. The five instrument measurement ranges are 100kΩ, 10kΩ, 1kΩ, 100Ω and 10Ω depending on the test frequency and selected constant source impedance. In MEAS DISPLAY (Pg 2/3) press [F1] so that the **A** box is highlighted*. Use the up arrow [↑] key to increase the range value or use the down arrow [↓] key to decrease the range value. The instrument default setting is A (Auto Range).

The screenshot shows the MEAS DISPLAY screen with the following content:

- Header: < MEAS DISPLAY >
- Measurements: Cs : -1.2 pF, D : 0.0522
- Range settings: RANGE: **H** 100k, SPEED: MEDIUM, TRIG.: INT., NEXT PAGE 2/3
- Function key: F1 Select measurement range
- Navigation controls:
 - ▲ Toggle between A and H mode
 - ▶ Move highlighted box to value
 - ▲ Increase range value: 100kΩ = max R
 - ▼ Decrease range value: 10kΩ, 1kΩ, 100Ω, 10Ω

* Use the up arrow [↑] key to toggle between A (Auto) and H (Hold). Use the right arrow [⇒] key to move the range value.

2.4.5 SPEED

Trading accuracy for speed, program the measurement speed of the 1715 instrument to Slow (2 measurements/second), Medium (8 measurements/second) or Fast (25 measurements/second). The basic LCR accuracy (0.2%) and D accuracy (0.002) are specified for the slow measurement speed. In MEAS DISPLAY (Pg 2/3), press [F2] so that the highlighted cursor is to the right of MEDIUM. Use the up arrow [↑] key to increase the speed or use the down arrow [↓] key to decrease the speed. The instrument default setting is MEDIUM (8 meas/second).

The screenshot shows the MEAS DISPLAY screen with the following information:

- Header: < MEAS DISPLAY >
- Range: H 100k
- Measurement results: Cs : -1.2 pF, D : 0.0522
- Speed: MEDIUM (highlighted with a cursor)
- TRIG.: INT.
- Next page: NEXT PAGE 2/3

To the right of the screen, the F2 key is shown with the label "Select measurement speed". Below it are two arrow keys:

- Up arrow: Increase speed: Slow/Medium/Fast (2 meas/sec, 8 meas/sec, 25 meas/sec)
- Down arrow: Decrease speed: Fast/Medium/Slow (25 meas/sec, 8 meas/sec, 2 meas/sec)

The accuracy of the 1715 instrument depends on the speed of the measurement. Basic Accuracy for LCR is $\pm 0.2\%$ and basic accuracy for DQ is ± 0.002 . Basic accuracy is specified for the speed equal to 2 measurements/second, temperature = $23^{\circ}\text{C} \pm 5^{\circ}\text{C}$, relative humidity (RH) $\leq 90\%$.

Table 2-4 lists the basic accuracy for $|Z| - \theta$. For measurements made in fast mode double the accuracy listed in Table 2-4.

Table 2-4: $|Z| - \theta$ Accuracy

Impedance $Z (\Omega)$	10M Ω	2.5% 0.6°	1.0% 0.5°	0.8% 0.4°	
	1M Ω	0.6% 0.4°	0.5% 0.3°	0.4% 0.25°	0.9% 1.9°
	100k Ω	0.4% 0.2°	0.3% 0.15°	0.2% 0.12°	0.6% 0.8°
	10k Ω	0.2% 0.1°			
	100 Ω	0.3% 0.15°	0.25% 0.12°	0.2% 0.1°	0.2% 0.12°
	10 Ω	0.4% 0.2°	0.3% 0.2°	0.25% 0.15°	0.3% 0.2°
	1 Ω	1.0% 0.8°	0.8% 0.8°	0.8% 0.8°	1.2% 1.0°
	0.1 Ω				
		100Hz	120Hz	1kHz	10kHz
		Frequency (Hz)			

More 1715 Accuracy Formulas

L, C & R Accuracy

For $Q \geq 10$ and $(D \leq 1)$, $|Z| =$

$$|Z_L| = |2\pi fL|$$

$$|Z_C| = |1/(2\pi fC)|$$

For $Q < 10$ and $(D > 1)$,

Multiply L accuracy by $[1 + (1/Q)]$

Multiply C accuracy by $(1 + D)$

D & Q Accuracy

For all D values:

$$\text{DF Accuracy} = \left[\frac{|Z| \text{ Accuracy } (\%)}{100} + \frac{\text{DF}}{50} \right] \times \left[1 + \sqrt{\frac{\text{FREQ}}{50000}} \right]$$

For all values of Q:

$$Q_{\text{ACCURACY}} = \left[\frac{\text{Accuracy } \%}{100} \right] + \left[|Q| \left[0.02 + \frac{\text{Accuracy } \%}{100} \right] \right] + \left[Q^2 \left[\frac{\text{Accuracy } \%}{100} \right] \right]$$

R Accuracy

For $Q \leq 0.1$:

$$\text{Accuracy of R} = \text{Accuracy of } |Z|$$

For $Q \geq 0.1$:

Multiply accuracy R by $(1 + Q)$

Figure 2-3 illustrates the frequency conversion charts for LC to Z, C to Z and L to Z.

1715 Accuracy Conversion Charts

LC — |Z| i

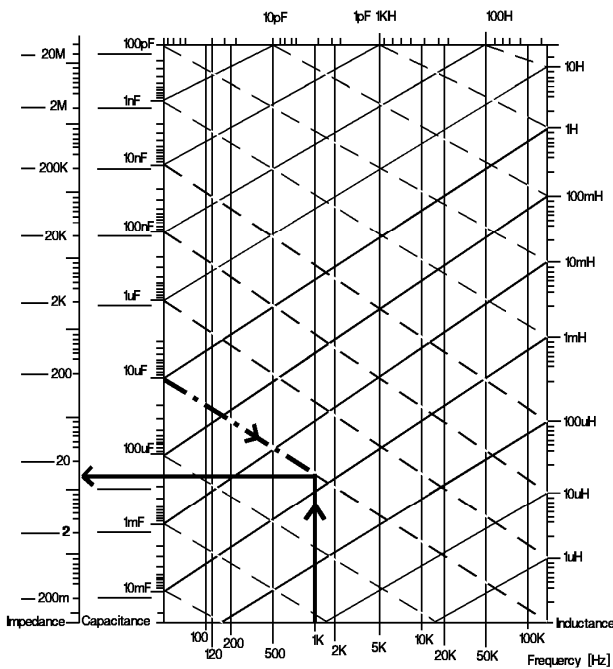
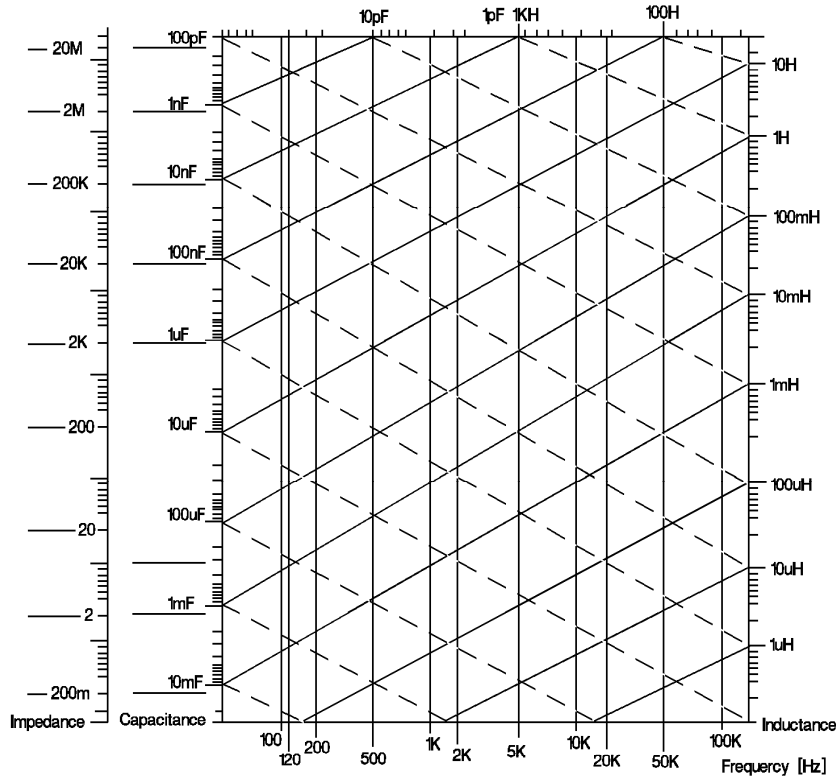

(b). C → |Z|

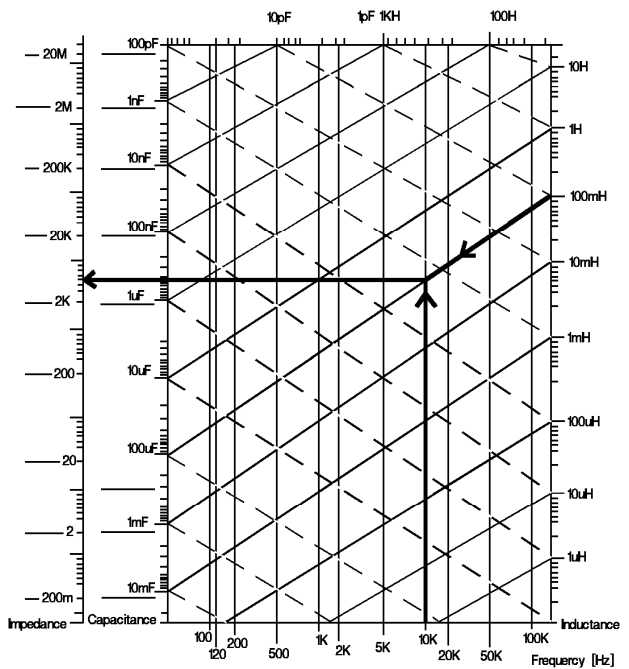

(c). L → |Z|

Figure 2-3: 1715 Accuracy Formula Conversion Charts

2.4.6 TRIGger

The 1715 instrument can be triggered manually, internally or externally. In MEAS DISPLAY (Pg 2/3), press [F3] so that the highlighted cursor is to the right of INT. Use the up arrow [↑] key to change the trigger or use the down arrow [↓] key to change the trigger. The instrument default setting is INT (internal trigger). When MANUAL trigger is selected, one measurement will be made each time the trigger is pressed. When EXTERNAL trigger is selected, one measurement will be made each time the external trigger is asserted by the handler. When INTERNAL trigger is selected, measurements are performed continuously when in [MEAS DISPLAY].

The screenshot shows the MEAS DISPLAY screen with the following information:

- Header: < MEAS DISPLAY >
- Measurements: Cs : -1.2 pF, D : 0.0522
- Settings: RANGE: A 100k, SPEED: MEDIUM, TRIG.: INT. []
- Footer: NEXT PAGE 2/3

Control buttons and labels:

- F3: Select measurement trigger
- ▲: Select trigger: INT, MAN, EXT
- ▼: Select trigger: INT, MAN, EXT

2.4.7 BINNING

The 1715 instrument has 8 pass/fail bins for sorting components by test result. To enable/disable the binning function, in MEAS DISPLAY (Pg 3/3) press [F2] so that the highlighted cursor is to the right of OFF. Use the up arrow [↑] key or down arrow [↓] key to switch the binning function ON/OFF. The instrument default setting is OFF. Setting the bin values is done within the MAIN INDEX menu. Refer to paragraph 2.5.1 for instructions on setup of Binning.

The screenshot shows the MEAS DISPLAY screen with the following information:

- Header: < MEAS DISPLAY >
- Measurements: Cs : -1.2 pF, D : 0.0522
- Settings: BIN : OFF [], COMP. : OFF
- Footer: NEXT PAGE 3/3

Control buttons and labels:

- F1: Enable/Disable binning function
- ▲: Enable/Disable binning function
- ▼: Enable/Disable binning function

The screenshot shows the MEAS DISPLAY screen with the following information:

- Header: < MEAS DISPLAY >
- Measurements: Cs : -1.2 pF, D : 0.0522, BIN: 0
- Settings: BIN : ON [], COMP. : OFF
- Footer: NEXT PAGE 3/3

2.4.8 COMPARE

The 1715 instrument has 8 pass/fail bins for sorting components by test result. To enable/disable the compare function, in MEAS DISPLAY (Pg 3/3), press [F3] so that the highlighted cursor is to the right of OFF. Use the up arrow [↑] key or down arrow [↓] key to switch the compare function ON/OFF*. The instrument default setting is OFF. Setting the comparison values is done within the MAIN INDEX menu. Refer to paragraph 2.5.4 for instructions on setup of Compare.

The first screenshot shows the MEAS DISPLAY menu with the following values: Cs : -1.2 pF, D : 0.0522, BIN : OFF, COMP. : OFF. The second screenshot shows: ΔCs : 0.00 %, D : 0.0522, PRI: LO, SEC: HI, BIN : OFF, COMP. : ON-Δ%. The legend for the F2 key shows: F2 (Enable/Disable compare function), ▲ (Enable/Disable compare function), ▼ (Enable/Disable compare function), ON-VAL (Absolute Value), ON-Δ (Delta Absolute Value), ON-Δ% (Delta Percent Absolute Value), and OFF (Compare Function: OFF).

* Refer to “Notes on Compare Settings”.

Notes on Compare Settings:

Setting COMPARE = **ON-VAL** will display the primary and secondary readings in addition to a **GO** (PASS). A **LO** reading is lower than the set nominal value and a **HI** reading is higher than the set nominal value.

Setting COMPARE = **ON-Δ** will display the difference between the measured value and the set nominal value. A **GO**, **LO**, or **HI** judgment is also displayed.

Setting COMPARE = **ON-Δ%** will display the percent difference between the measured value and the set nominal value. A **GO**, **LO**, or **HI** judgment is also displayed.

2.5 MAIN INDEX

Within the 1715 instrument's MAIN INDEX are the Binning, Compare and Correction functions. To access these functions press [MAIN INDEX] and the display should look as shown in Figure 2-4.

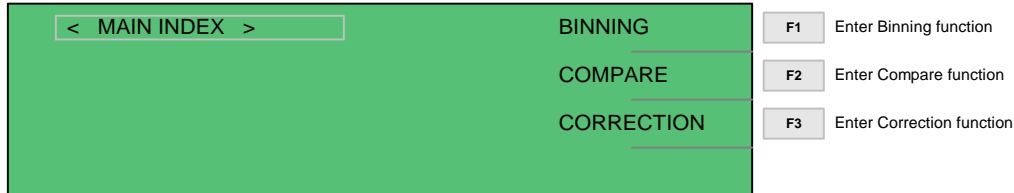
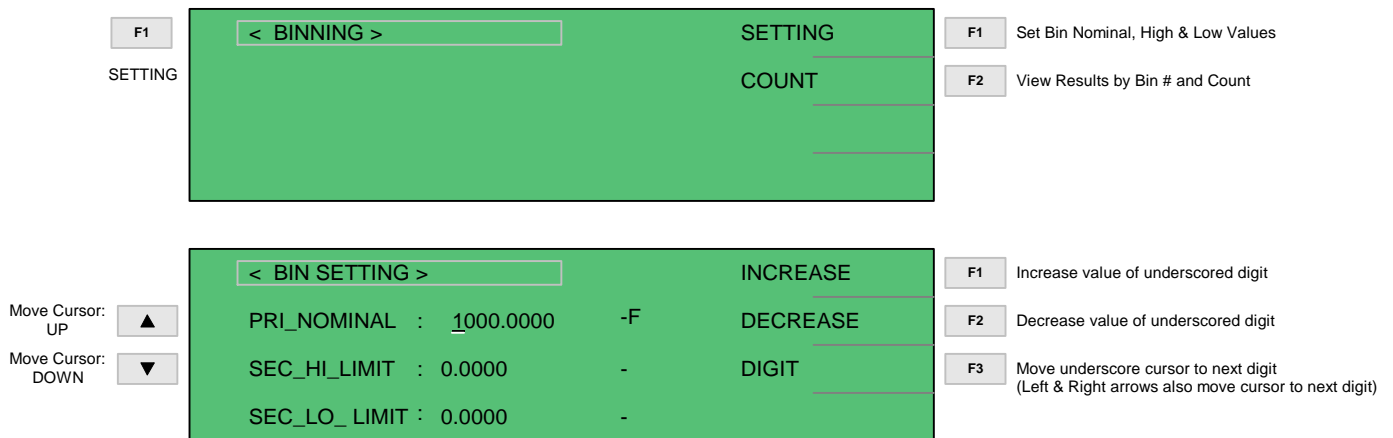

Figure 2-4: MAIN INDEX

2.5.1 BINNING

To set the bin functions for the 1715 instrument, press [MAIN INDEX] then [F1] = BINNING.



- Press [F1] = BIN SET and to enter the BIN SET Display and set the nominal, high and low values for the primary parameter.
- To select the nominal, high or low value, move the underscore cursor UP using the up arrow [↑] or to move it down using the down arrow [↓].
- Press [F1] = INCREASE to increase the value of the underscored digit.
- Press [F2] = DECREASE to decrease the value of the underscored digit.
- Press [F3] = DIGIT to move the underscored digit right. The left [←] and right [→] arrow keys also move the underscored digit left or right on a single line.
- The units of the values can be selected using the INCREASE and DECREASE when the underscore cursor is in the right most position.

When the nominal, secondary high and secondary low values are set, use the down [↓] arrow key to move the underscore cursor SEC_LO_LIMIT: 0.0000 down to view the high and low percent settings for bins 1-8.

BIN Set and BIN Count

After setting the SEC_LO_LIMIT: 0.0000 value, press the down [↓] arrow key to view bins 1-3.
Press the down [↓] arrow key again to view bins 4-6.
Press the down [↓] arrow key again to view bins 7-8.
Press the [MAIN INDEX] key to return to the MAIN INDEX BINNING screen.
Press the [F2] = COUNT to view the bin count for bins 1-8 and the OUT bin.

In the BIN COUNT screen:

Press [F1] = RESET to clear the contents of the bins.
Press [MAIN INDEX] when finished.

The screenshot shows the BIN COUNT screen with a green background. At the top left, there is a box containing "< BINNING >". To the right of this box are the words "SETTING" and "COUNT". Below "SETTING" and "COUNT" are three horizontal lines. On the left side of the screen, there is a box labeled "F2" and the word "COUNT". On the right side, there are two boxes: the top one is labeled "F1" and contains the text "Set Bin Nominal, High & Low Values", and the bottom one is labeled "F2" and contains the text "View Results by Bin # and Count".

0 : 4	4 : 0	RESET
1 : 0	5 : 0	8 : 4
2 : 0	6 : 0	X : 4
3 : 0	7 : 0	T : 4

On the right side of the table, there are three horizontal lines. Below the table, there is a box labeled "F1" and the text "Reset bin counts to 0."

Two of the most common methods of sorting results into bins are using nested limits or sequential limits.

Nested Limits

Nested limits are a natural choice for sorting components by % tolerance around a single nominal value with the lower bins narrower than the higher numbered bins. Nested limits for three bins are illustrated in Figure 2-5. Note that the limits do not have to be symmetrical (Bin 3 is $-7%$ and $+10%$).

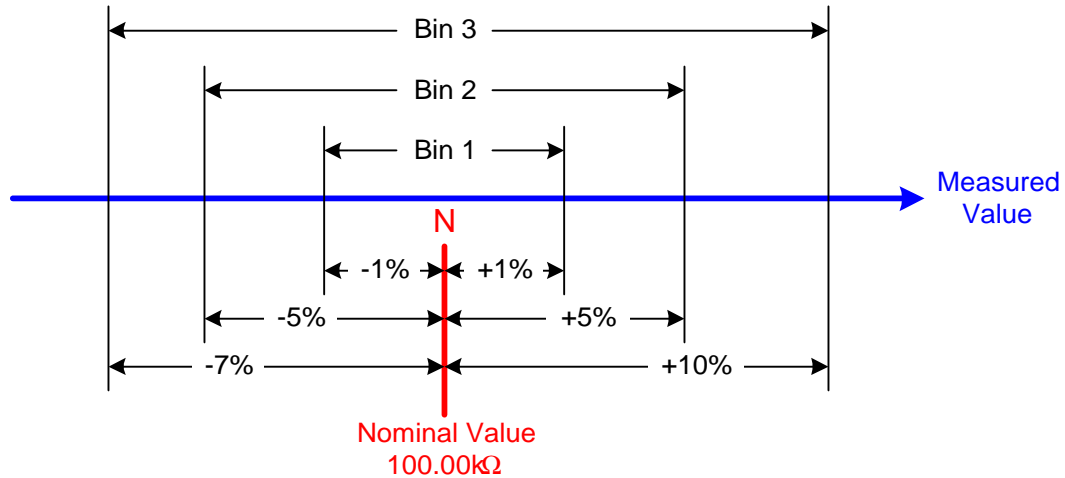

Figure 2-5: Nested Limits

Sequential Limits

Sequential limits are a natural choice when sorting components by absolute value. Figure 2-6 illustrates the use of sequential limits for a total of three bins. Sequential bins do not have to be adjacent. Their limits can overlap or have gaps depending upon the specified limit. Any component that falls into an overlap between bins would be assigned to the lower numbered bin and any component that falls into a gap between bins would be assigned to the overall fail bin.

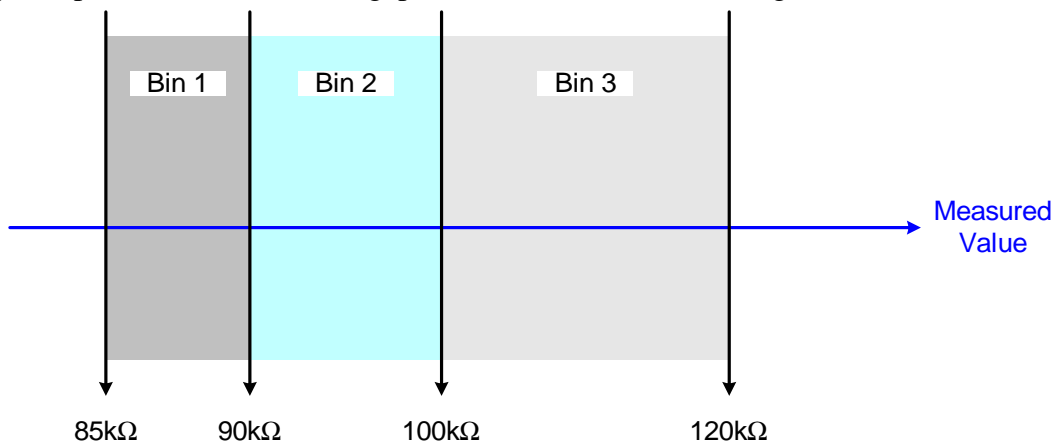

Figure 2-6: Sequential Limits

2.5.2 COMPARE

To set up a comparison test, use the COMPARE function. To access the COMPARE function, press [MAIN INDEX] then press [F2] = COMPARE. Press [F1] = SETTING to set the primary nominal high and low judgment values. Press [F2] = COUNT to view the COMPARE results and counts.

<p>F2 COMPARE</p>	<p>< MAIN INDEX ></p> <p>BINNING</p> <p>COMPARE</p> <p>CORRECTION</p>	<p>F1 Enter Binning function</p> <p>F2 Enter Compare function</p> <p>F3 Enter Correction function</p>
<p>F1 SETTING</p>	<p>< COMPARE ></p> <p>SETTING</p> <p>COUNT</p>	<p>F1 Set Bin Nominal, High & Low Values</p> <p>F2 View Results by Bin # and Count</p>
Set Primary Limits		
<p>Move Cursor: UP ▲</p> <p>Move Cursor: DOWN ▼</p>	<p>< COMP. SETTING > Cs - D</p> <p>PRI_NOMINAL : <u>±</u>300.000 -F</p> <p>PRI_HI_LIMIT : 500.000 -F</p> <p>PRI_LO_LIMIT : 20.0000 -F</p>	<p>F1 Increase value of underscored digit</p> <p>F2 Decrease value of underscored digit</p> <p>F3 Move underscore cursor to next digit (Left & Right arrows also move cursor to next digit)</p>
Set Secondary Limits		
<p>Move Cursor: UP ▲</p> <p>Move Cursor: DOWN ▼</p>	<p>< COMP. SETTING > Cs - D</p> <p>SEC_HI_LIMIT : <u>0</u>.0000 -</p> <p>SEC_LO_LIMIT : 0.0000 -</p>	<p>F1 Increase value of underscored digit</p> <p>F2 Decrease value of underscored digit</p> <p>F3 Move underscore cursor to next digit (Left & Right arrows also move cursor to next digit)</p>
<p>MAIN INDEX</p>	Exit Compare Settings	

Continued on Next Page.

Compare Function Continued

Note that there are two pages within the Compare Setting menu: Primary and Secondary. Use the up and down arrows to move the underscore cursor down the list to each parameter. When all the comparison limits have been entered, press [MAIN INDEX] to exit Compare Setting and return to [COMPARE]. Press [F2] = COUNT to view the Comparison Count by parameter and GO, HI or LO.

The screenshot shows two screens of the Compare Function menu. The top screen is a green background with a white border. At the top left, there is a button labeled 'F2' and the text 'COUNT'. The main area contains a green box with '< COMPARE >' and 'SETTING' on the right. Below 'SETTING' is 'COUNT'. To the right of the screen are two buttons: 'F1 Set Bin Nominal, High & Low Values' and 'F2 View Results by Bin # and Count'. The bottom screen is also green with a white border. It has three columns: 'PRIMARY', 'SECONDARY', and 'RESET'. The 'PRIMARY' column has 'GO : 0', 'HI : 0', and 'LO : 0'. The 'SECONDARY' column has 'GO : 0', 'HI : 0', and 'LO : 0'. The 'RESET' column has 'TOTAL:' and '0'. To the right of the screen is a button labeled 'F1 Reset bin counts to 0'.

Notes on Compare Settings:

Setting COMPARE = ON-VAL will display the primary and secondary readings in addition to a GO (PASS). A LO reading is lower than the set nominal value and a HI reading is higher than the set nominal value.

Setting COMPARE = ON-Δ will display the difference between the measured value and the set nominal value. A GO, LO, or HI judgment is also displayed.

Setting COMPARE = ON-Δ% will display the percent difference between the measured value and the set nominal value. A GO, LO, or HI judgment is also displayed.

2.5.3 CORRECTION

The 1715 instrument provides automatic offset for lead and/or fixture effects. During the offset process a correction is made (subtracted out) as the result of lead leakage current and stored in instrument memory to be applied to ongoing measurements. For maximum measurement accuracy it is recommended that the CORRECTION function be performed on the 1715 instrument after power up, any time the test parameters are changed and any time the test leads or fixture is changed.

Prior to performing the CORRECTION function:

- Allow the instrument to warm up for 15 minutes.
- Connect the Test cables (or fixture) to the output connectors (BNC terminals).
- Program the test steps.

With the instrument in STAND-BY status (MEAS DISPLAY shown on display):

- Press [MAIN INDEX]
- Press [F3] = CORRECTION
- Press [F1] = OPEN (or [F2] = SHORT) to select zero function.
- Press [F1] = SINGLE or [F2] = MULTI to select frequency.
- Follow instructions on display: i.e.: “Open circuit test leads”.
- Press [TRIGGER] button.
- Wait while instrument gets CORRECTION value.
- Press [F4] to exit Correction Function.

NOTE:

When SINGLE is selected, the 1715 instrument performs an open/short at the programmed test frequency.
When MULTI is selected, the 1715 instrument performs the open/short at all 4 test frequencies.

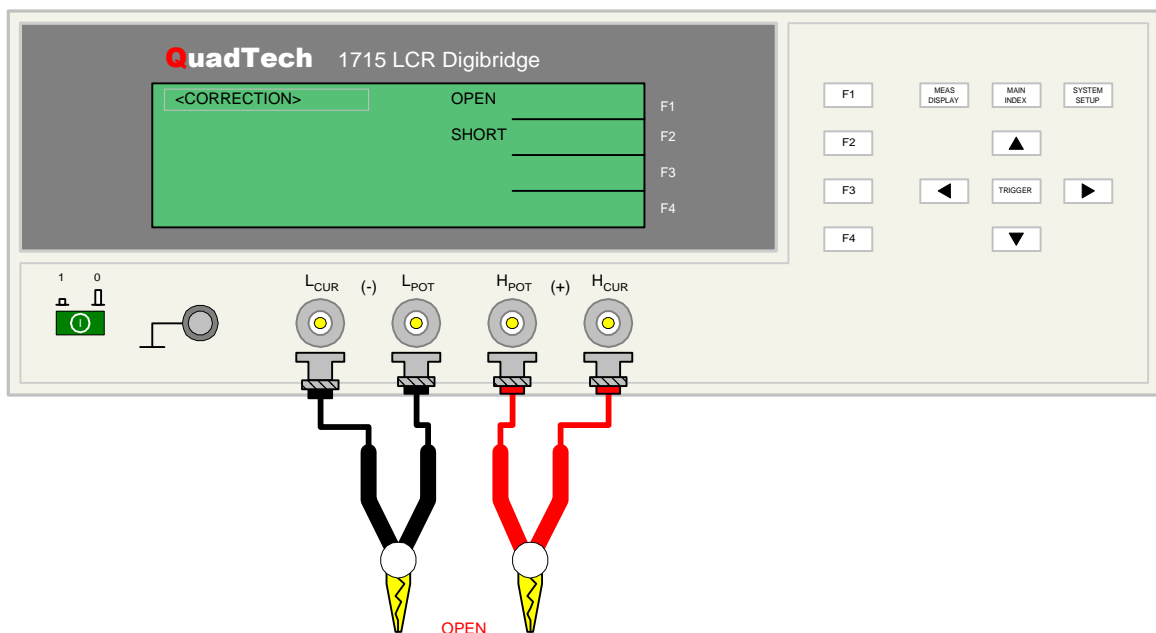
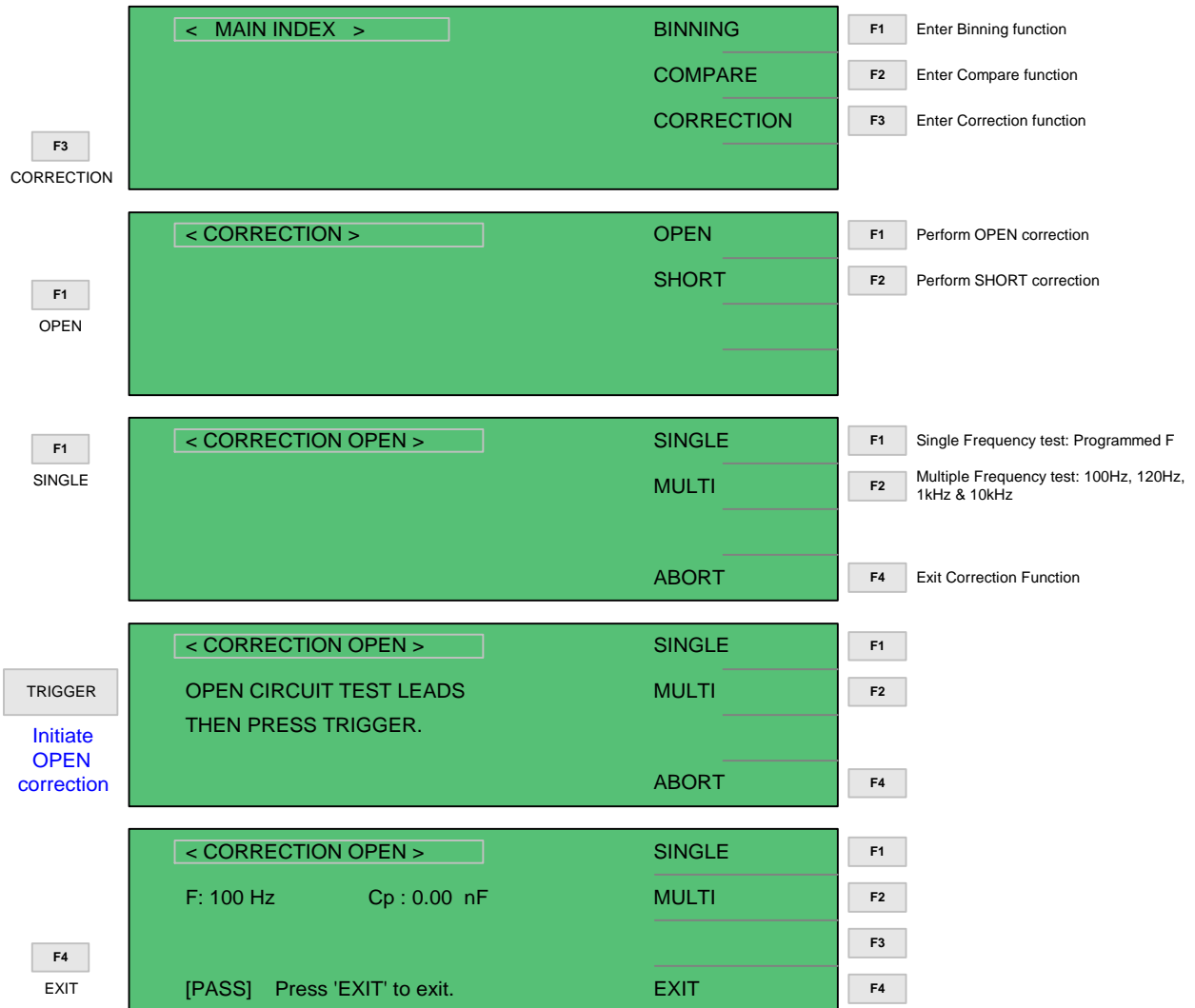

Figure 2-7: OPEN Configuration using Kelvin Clip Test Leads

CORRECTION: OPEN

Figure 2-7 illustrates the connection of the Kelvin Clip test leads for an open correction. The MAIN INDEX display menus corresponding to the OPEN operation are illustrated below.



CORRECTION: SHORT

Figure 2-8 illustrates the connection of the Kelvin Clip test leads for a short correction. The MAIN INDEX display menus corresponding to the SHORT operation are illustrated below.

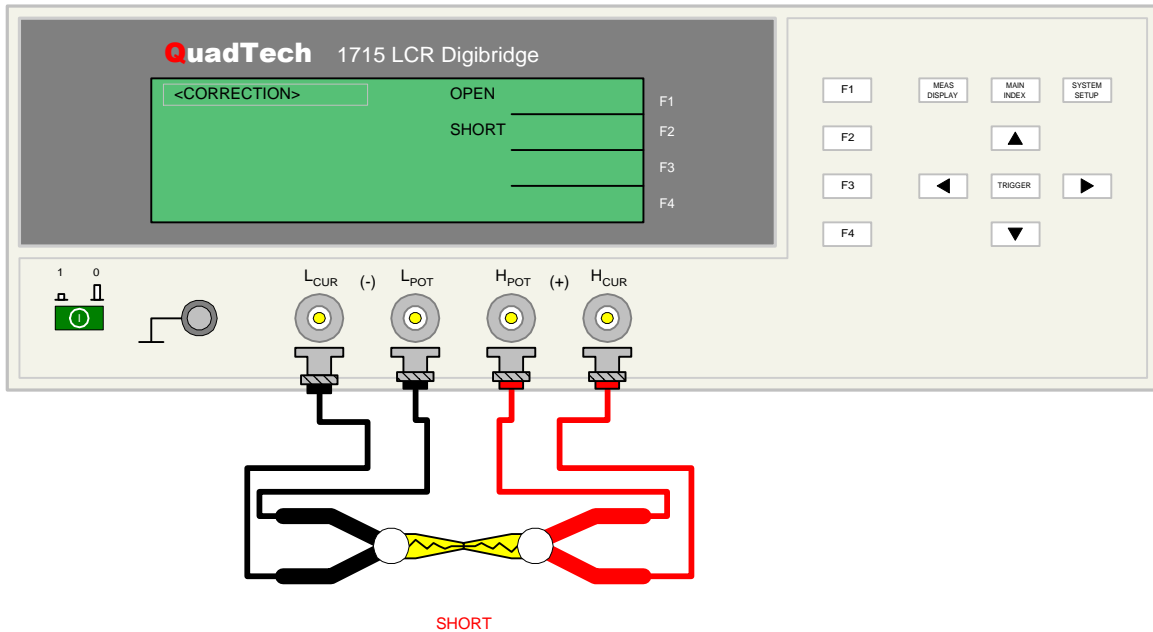
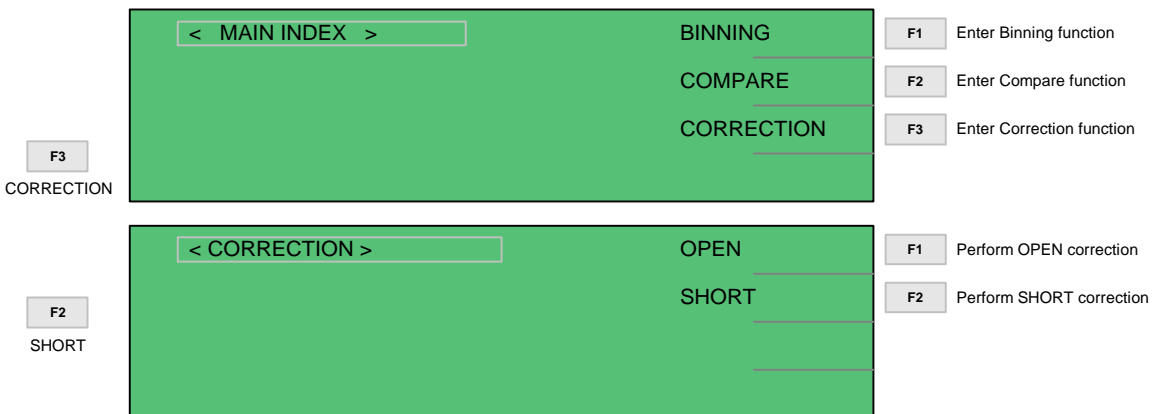

Figure 2-8: SHORT Configuration using Kelvin Clip Test Leads

To access the SHORT correction operation, press [MAIN INDEX] then [F3] = CORRECTION.



CORRECTION: SHORT - continued

Press [F3] = SHORT to select the SHORT configuration. Short test leads together then press [TRIGGER] to initiate short correction measurement.

<p>F1 SINGLE</p>	<p>< CORRECTION SHORT ></p> <p>SINGLE</p> <p>MULTI</p> <p>ABORT</p>	<p>F1 Single Frequency test: Programmed F</p> <p>F2 Multiple Frequency test: 100Hz, 120Hz, 1kHz & 10kHz</p> <p>F4 Exit Correction Function</p>
<p>TRIGGER</p> <p>Initiate SHORT correction</p>	<p>< CORRECTION SHORT ></p> <p>SHORT CIRCUIT TEST LEADS THEN PRESS TRIGGER.</p> <p>SINGLE</p> <p>MULTI</p> <p>ABORT</p>	<p>F1</p> <p>F2</p> <p>F4</p>
<p>F4 EXIT</p>	<p>< CORRECTION SHORT ></p> <p>F: 100 Hz Rs : 0.000 -Ω</p> <p>[PASS] Press 'EXIT' to exit.</p> <p>SINGLE</p> <p>MULTI</p> <p>EXIT</p>	<p>F1</p> <p>F2</p> <p>F4</p>

NOTE:
Perform the CORRECTION functions any time the test leads or test fixtures are changed or any time the test parameters are changed.

NOTE:
When SINGLE is selected, the 1715 instrument performs an open/short at the programmed test frequency. When MULTI is selected, the 1715 instrument performs the open/short at all 4 test frequencies.

2.6 Connection to Device under Test

Figure 2-9 illustrates the connection of the 1715 LCR to a single DUT using the 1700-03 Kelvin Clip Cable lead set. The red Kelvin clip/BNCs are connected between the H_{POT} and H_{CUR} (+) terminals on the 1715 unit and the high side of the device under test. The black Kelvin clip/BNCs are connected between the L_{POT} and L_{CUR} (-) terminals on the 1715 unit to the low side of the DUT.

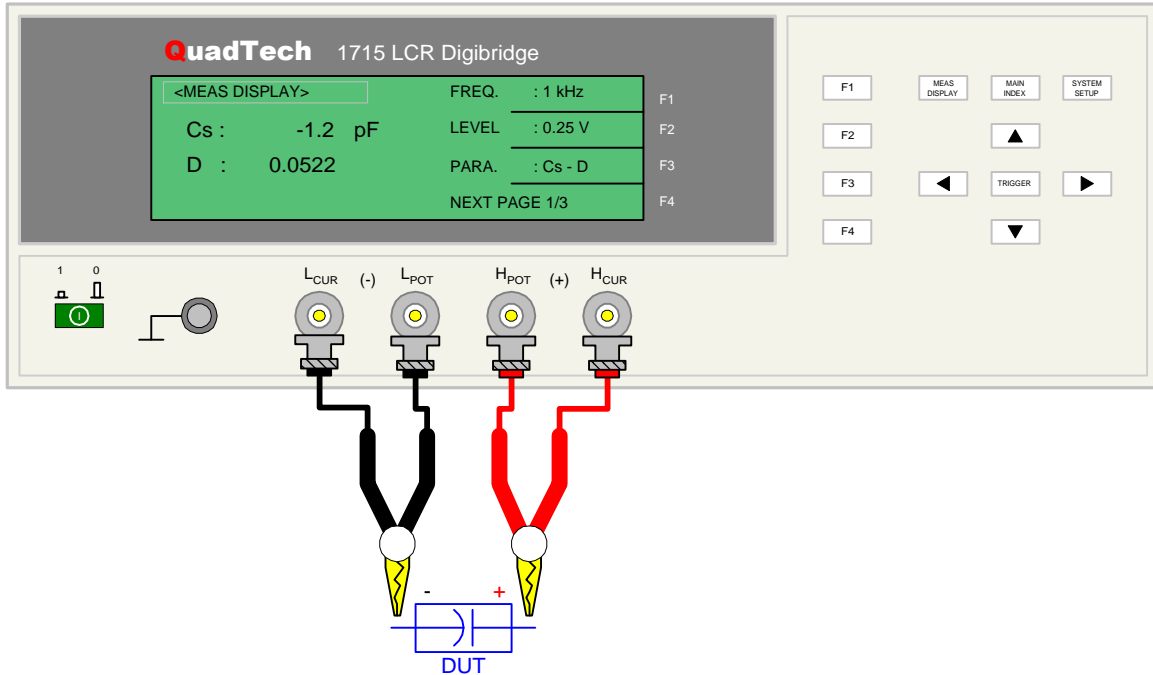

Figure 2-9: 1700-03 Kelvin Clip Test Leads

There are a variety of test leads and fixtures available for the 1715 LCR Meter as listed in Table 2-5 and illustrated in Figure 2-9 through 2-14.

Table 2-5: 1715 LCR Meter Test Leads & Fixtures

Description	QuadTech P/N	Figure
Axial/Radial Component Test Fixture	1700-01	2-10
Axial/Radial Remote Test Fixture	1700-02	2-11
Lead Set: 4 BNC Connectors to 2 Kelvin Clips	1700-03	2-9
Lead Set: 4 BNC Connectors to 4 Banana Plugs	1700-04	2-12
Lead Set: 4 BNC Connectors to Chip Component Tweezers	7000-05	2-13
Low Voltage Chip Component Test Fixture	7000-07	2-14

NOTE:

For proper operation, the $H_{CUR}/H_{POT}/I_{CUR}/I_{POT}$ cable shields must be connected together at the DUT. This connection is already made using the 1715 recommended accessory leads.

If the shields are not tied together, then at higher frequencies a resonance may occur which could cause erroneous capacitance readings.

Connection to Device under Test – continued

Figure 2-10 illustrates the connection of the 1700-01 axial/radial component test fixture to the 1715 LCR meter. Included with the 1700-01 fixture are 2 axial lead adapters and a short.

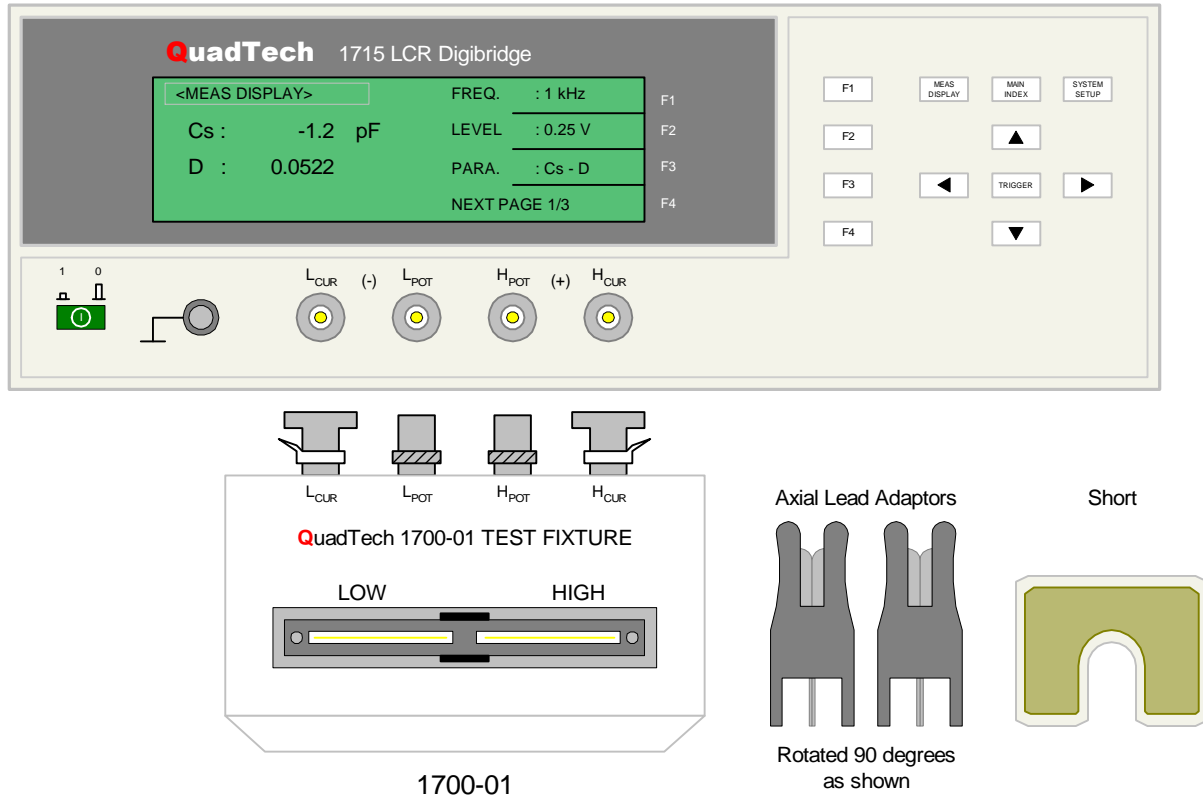

Figure 2-10: 1700-01 Axial/Radial Component Test Fixture

Figure 2-11 illustrates the connection of the 1700-02 axial/radial remote test fixture to the 1715 LCR meter. Included with the 1700-02 fixture are 2 axial lead adapters and a short.

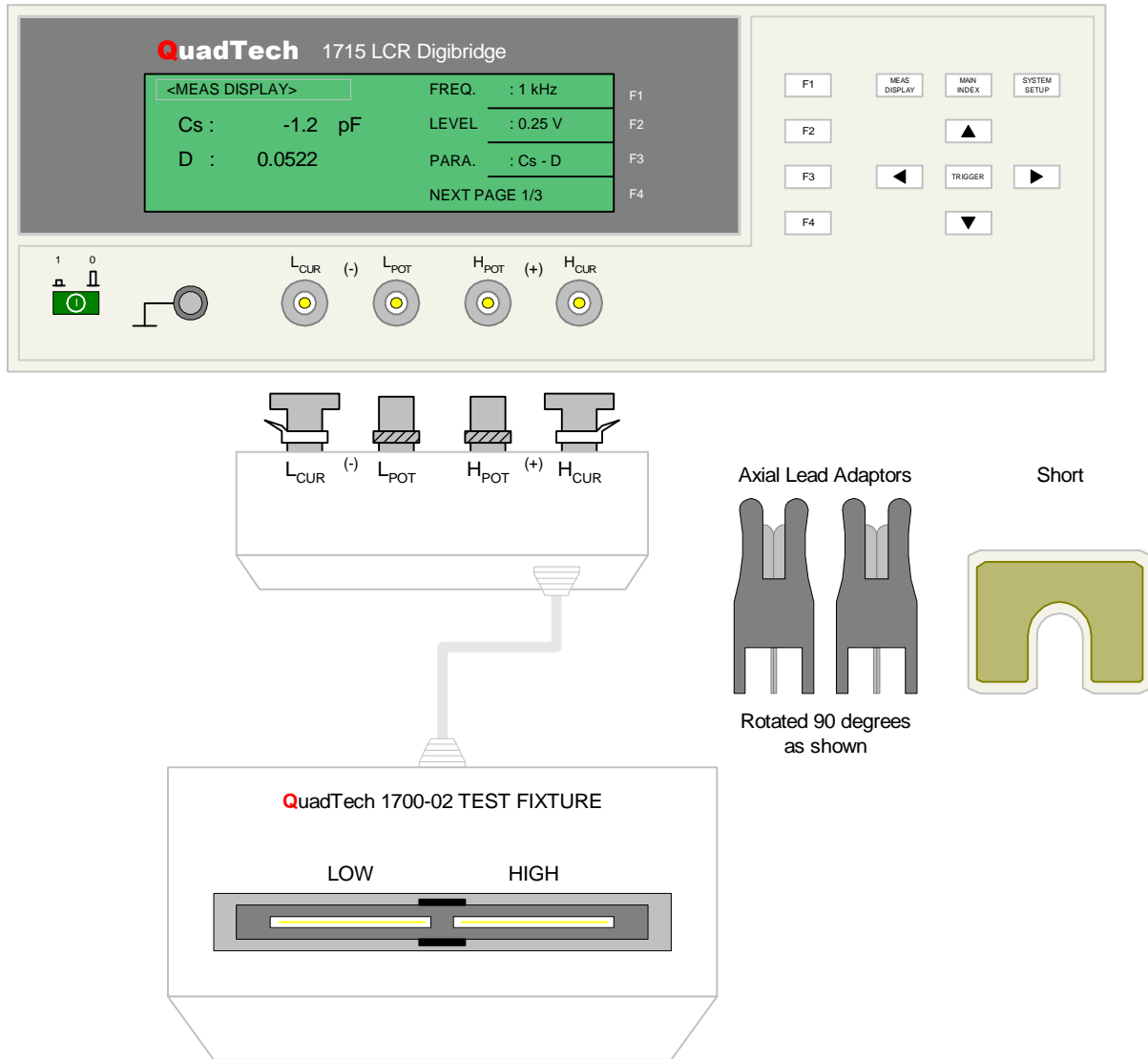

Figure 2-11: 1700-02 Axial/Radial Remote Test Fixture

Figure 2-12 illustrates the connection of the 1700-04 BNC/Banana Plug lead set to the 1715 LCR meter.

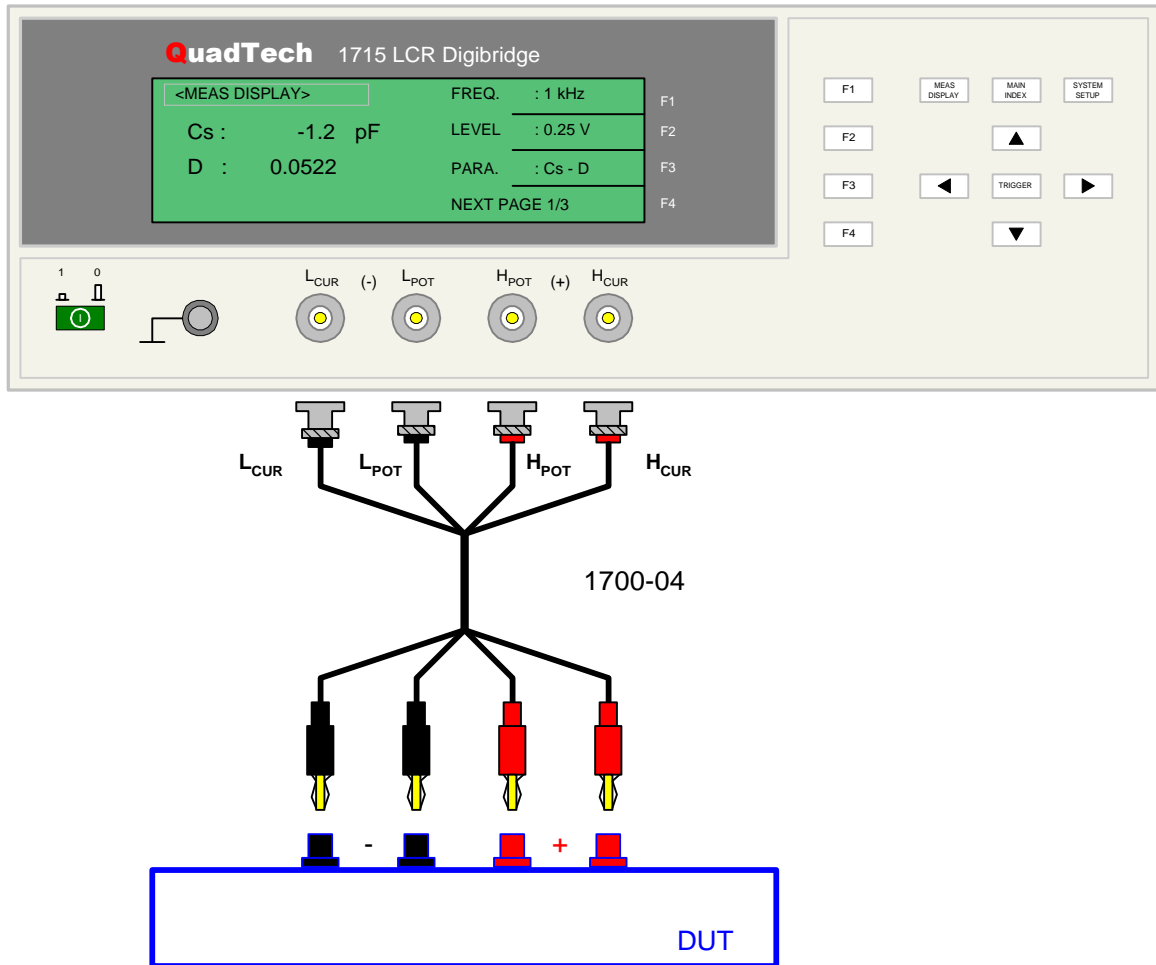

Figure 2-12: 1700-04 BNC/Banana Plug Test Lead Set

Figure 2-13 illustrates the connection of the 1700-05 Component Tweezers cable lead set to the 1715 LCR meter. This provides a 4-terminal connection to even the smallest of devices.

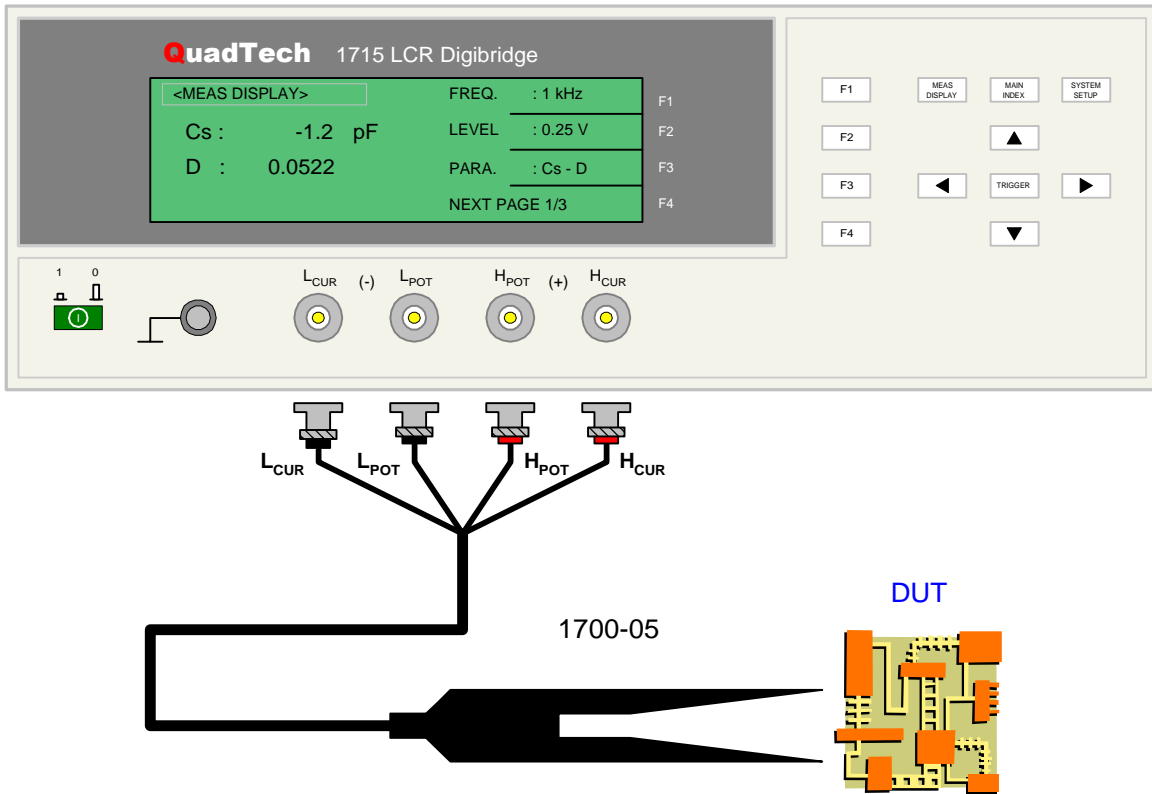

Figure 2-13: 1700-05 BNC to Chip Component Tweezers Cable Lead Set

Figure 2-14 illustrates the 7000-07 Low Voltage Chip Component (SMD) test fixture available for use with the 1715 LCR Meter.



Figure 2-14: 7000-07 Low Voltage Chip Component Test Fixture

2.7 Measurement Procedure

Before a measurement is made verify the following:

1. 1715 instrument [POWER] ON.
2. 15-minute warm-up.
3. Test parameters programmed and shown on MEAS DISPLAY.
4. Test cables or fixture connected.
5. CORRECTION function initiated.
6. Device under test connected.

The operator has the option of performing a test at power-up conditions (test conditions at which the instrument was last powered down). Refer to paragraphs 2.4 – 2.5 for test programming. To store the test conditions, press [SYSTEM SETUP] after setting the conditions and before powering down.

To initiate a test:

- Press [TRIGGER].
- The test voltage is shut **off** when all test steps are completed,
- **OR** when a test result is judged a FAIL per programmed test limits.
- The test result is displayed on MEAS DISPLAY

The 1715 instrument judges the measurement value based on the BINNING and COMPARE functions set up previously. Refer to paragraphs 2.5.1 and 2.5.2 for instructions on setting these judgment parameters. Upon completion of the test the output voltage is terminated and the display shows the test result.

Section 3: Interface

3.1 RS-232 Interface

3.1.1 RS-232 Pin Configuration

The 1715 instrument comes standard with an RS232 Interface for remote operation. Connection is through the black/silver 9-pin connector labeled 'RS232' on the rear panel of the 1715 instrument. Figure 3-1 illustrates the designation of the pins on the RS232 connector. The connection cable must be a 'straight through' cable for the 1715 unit to communicate.

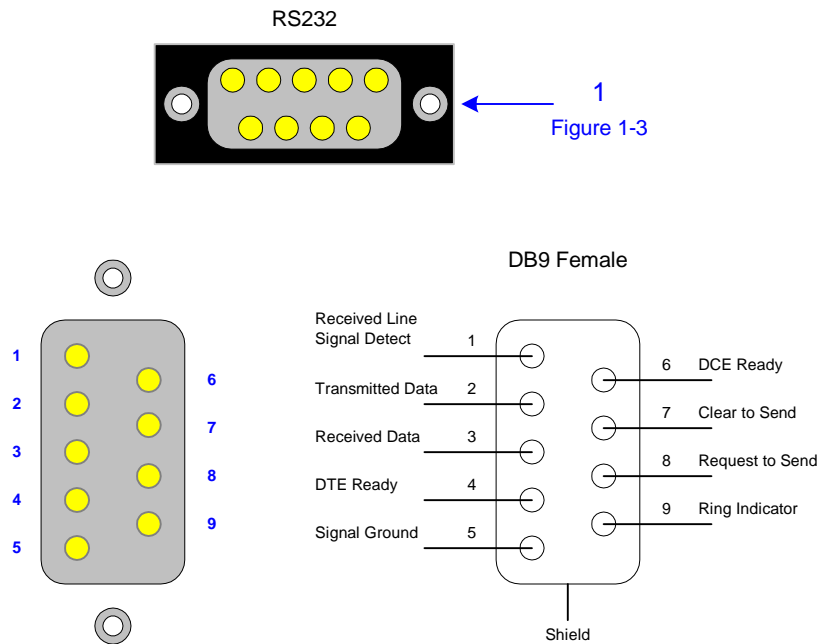

Figure 3-1: RS-232 Interface Pin Configuration

3.1.2 RS232 Specifications

Data Bits:	8
Stop Bits:	1
Parity:	None, Odd, Even
Baud Rate:	1200, 2400, 4800, 9600, 19200 Or 38400bps, Software selectable
EOS:	LF or CR + LF
Echo:	Off

Refer to paragraph 2.3.3.10. Setting the Baud Rate is done in the SYSTEM CONFIGURATION function under SYSTEM SETUP settings:

- From the STAND BY display, press [SYSTEM SETUP]
- Press [F3] = SYSTEM CONFIG.
- Press [↓] = until the box next to BAUD RATE is highlighted.
- Press [F1] = INCREASE or [F2] = DECREASE to select baud rate.
- Press [F4] to EXIT

3.1.3 RS232 Commands

The command set for the RS232 interface is the same as the IEEE-488 interface command set listed in paragraphs 3.2.3 through 3.2.5 of this instruction manual.

NOTE

CR + LF are necessary end codes for the RS232 commands.

NOTE

Press [F1] [F4] [SYSTEM SETUP] to get the 1715 instrument out of remote mode.

3.1.4 Sample QuickBasic Program

```
CLS
REM This is a simple program for the 1715 LCR meter
REM This is for RS232 communication and reads *idn from 1715
REM You must use a straight through cable
REM You must enable RS232 interface in System Setup menu of 1715
REM baud rate = 9600
REM to change com1, com2 in OPEN statement depending upon your computer

PRINT "Calculating Delay Loops ....."
REM delay correction routine
q = 1
DO WHILE ENVIRON$(q) <> ""
    IF LEFT$(ENVIRON$(q), 7) = "MACHINE" THEN
        qq = q
        mn = VAL(RIGHT$(ENVIRON$(q), 1))
        mn$ = RIGHT$(ENVIRON$(q), 1)
    END IF
    q = q + 1
LOOP

t1 = TIMER
s = 0
FOR I = 1 TO 30000
NEXT I
t2 = TIMER
k = t2 - t1

REM open com port as #1
OPEN "COM1:9600,n,8,1,cs,ds" FOR RANDOM AS #1:

REM Get identification string from 1715 Series
FOR j = 1 TO 100000: NEXT j
PRINT #1, "*idn?"; CHR$(13); CHR$(10)
FOR j = 1 TO 100000: NEXT j
GOSUB cget
r45$ = INPUT$(x, #1)
PRINT r45$
CLOSE #1
PRINT "End of Program"
END

cget:
' subroutine to get serial input loop until first character is received
DO WHILE (LOC(1) = 0)
FOR j = 1 TO k2: NEXT j
    LOOP
' then get the rest of the string
y = x + LOC(1)
DO WHILE (x <> y)
y = x
FOR j = 1 TO k2 / 10: NEXT j
x = LOC(1)
LOOP
'PRINT x
RETURN
```

3.2 IEEE-488 Interface

3.2.1 Pin Configuration

An IEEE-488 Interface (illustrated in Figure 3-2) is an available option for the 1715 instrument. Connection is through the blue 24-pin connector labeled 'IEEE-488 INTERFACE' on the rear panel of the 1715 instrument. This interface can be used to connect a system containing a number of instruments and a controller in which each meets IEEE Standard 488.2 (Standard Digital Interface for Programmable Instrumentation).

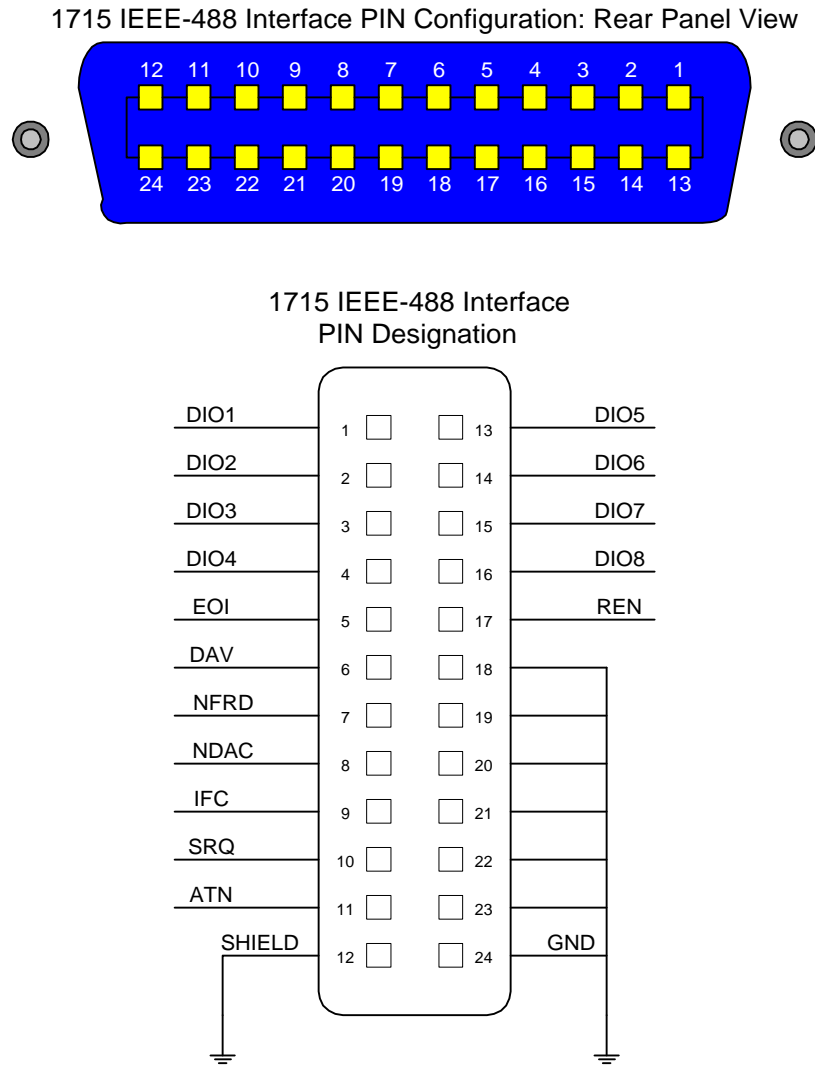

Figure 3-2: IEEE-488 Interface Pin Configuration

Table 3-1 lists the IEEE-488 Interface pin designations by pin number, signal name and pin function. Bus and driver information is also listed.

Table 3-1: IEEE-488 Interface Pin Designations

Bus	Driver	Signal Name	Pin Number	Function
Handshake	3 States	DAV	6	Low State: "Data is Available" and valid on DI01 through DI08
	Open Collector	NRFD	7	Low State: At least one Listener on the bus is "Not Ready For Data"
	Open Collector	NDAC	8	Low State: At least one Listener on the bus is "Not Accepting Data"
Control	3 States	ATN	11	"Attention" specifies 1 of 2 uses for the DI01 through DI08 lines: Low State: Controller command messages High State: Data bytes from the Talker device
	3 States	IFC	9	"Interface Clear" Low State: Returns portion of interface system to a known quiescent state
	Open Collector	SRQ	10	"Service Request" Low State: A Talker or Listener signals (to the controller) need for attention in the midst of the current sequence of events.
	3 States	REN	17	"Remote Enable" Low State: Enables each device to enter remote mode when addressed to listen. High State: All devices revert to Local control.
	3 States	EOI	5	"End of Identify" If ATN is in HIGH state, then EOI LOW state indicates the end of a multiple-byte data transfer sequence. If ATN is in LOW state, then EOI LOW state indicates a parallel poll.
Data	Open Collector	DI01	1	The 8-Line Data Bus. If ATN is in LOW state, then the bus conveys interface messages. If ATN is in HIGH state, then the bus conveys device-dependent messages. (Example: carries remote control commands from the controller or from a talker device)
		DI02	2	
		DI03	3	
		DI04	4	
		DI05	13	
		DI06	14	
		DI07	15	
		DI08	16	

3.2.2 IEEE-488 Interface Function Codes and Messages

The IEEE-488 (GPIB) address is defined under the SYSTEM SETUP in the SYSTEM CONFIG menu. Press [SYSTEM SETUP], then the numerical key [F3] to enter the SYSTEM CONFIG menu. Press down arrow [↓] to enter the GPIB ADDRESS code. To select a new IEEE-488 address, use the function keys. Refer to paragraph 2.3.3.6 for more information. The default setting for the IEEE address is 17.

Table 3-2 defines the IEEE-488 interface codes and their function. Table 3-3 defines the IEEE-488 interface messages the 1715 instrument responds to and their function.

Table 3-2: IEEE-488 Interface Functions

Code	Function
SH1	Source Handshake (Talker)
AH1	Acceptor Handshake (Listener)
T6	Basic Talker Function
	Serial Poll Function
	Listener-specified Talker Release Function
	No TALK-ONLY Function
L4	Basic Listener Function
	Talker-specified Listener Release Function
SR1	Service Request Function
RL1	All Remote/Local Functions
PP0	No Parallel Poll Function
DC1	Device Clear Function
DT1	Device Trigger Function
C0	No Controller Functions

Table 3-3: IEEE-488 Interface Messages

Interface Message	Function	Description
GTL	Go To Local	Only addressed devices that receive this command are set to local mode. Cancels the remote control mode, making the front panel switches operative.

NOTE

Press [F1] [F4] [SYSTEM SETUP] to get the 1715 instrument out of remote mode.

Table 3-4 lists the IEEE-488 interface commands the 1715 instrument accepts to set or query a parameter value. Paragraphs 3.2.3 through 3.2.5 detail command function, format, return value and description.

Table 3-4: IEEE-488 Commands

Command	Name	Function	Output Format
*CLS	Clear Status	Clear standard event status register. Clear status bit group register except for bit 4 (MAV)	
*ESE	Event Status Enable	Enable standard event status register value.	0 – 255
*ESE?	Event Status Enable	Query standard event status of device enable register	0 – 255
*ESR?	Event Status Register	Query standard event register value of device. After this command, the standard register is cleared to 0.	0 – 255
*IDN?	Identification	Query/Read basic device data. (A comma separates the identification fields.)	4 ID: Manufacturer, Device Model, Serial Number, Firmware Version
*RST	Reset	Reset Device.	
*SRE	Service Request Enable	Enable service request register value.	0 – 255
*SRE?	Service Request Enable	Query/Read service request register value.	0 – 255
*TRG	Trigger Bus	Trigger the 1715 instrument	
*TST?	Self Test	Perform self test & report error	0 = no error

NOTE

Press [F1] [F4] [SYSTEM SETUP] to get the 1715 instrument out of remote mode.

3.2.3 IEEE-488 Commands

Figure 3-2 illustrates the programming commands accepted by the IEEE-488 interface of the 1715 instrument. The commands are written in tabular format as a single reference to view all the commands. The command format and examples are detailed in paragraphs 3.2.4 – 3.2.5.

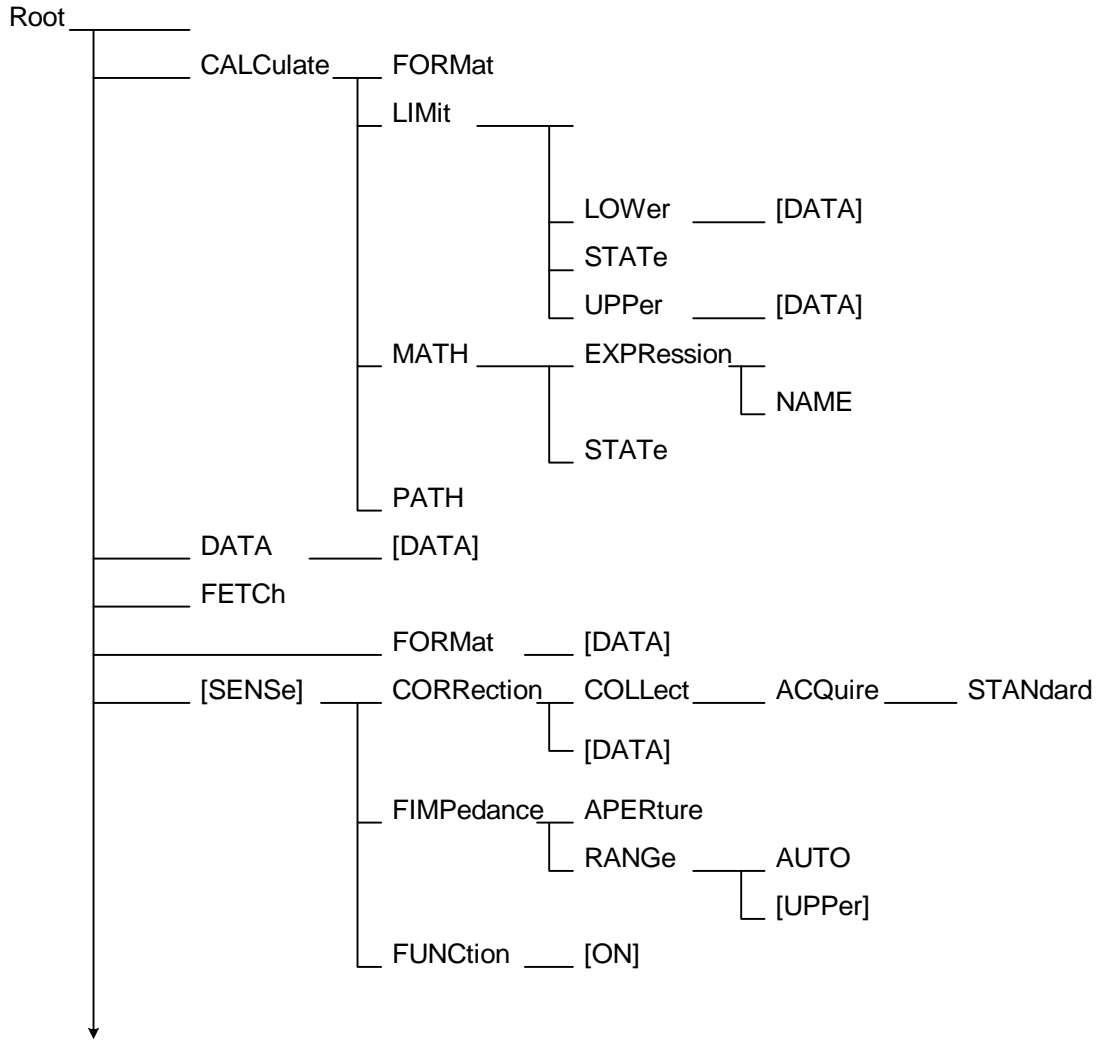

Continued on next page

Figure 3-2a: IEEE-488 Commands

Figure 3-2 Continued: Tabular format of IEEE-488 Commands

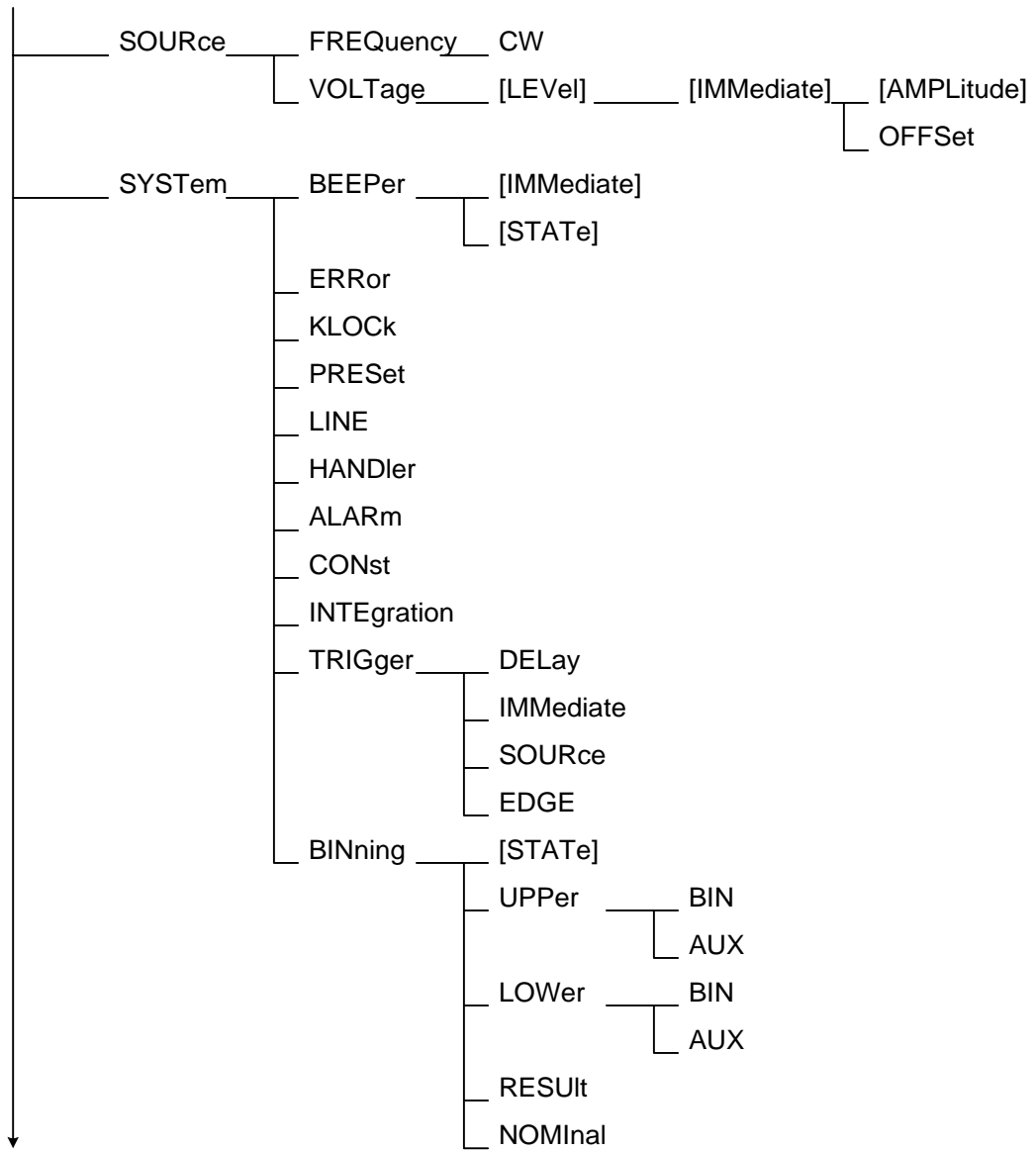

Figure 3-2b: IEEE-488 Commands

3.2.4 IEEE-488 Command Format

The IEEE-488 commands are configured in Root format. There are six levels of the instruction from top to bottom. Follow the specific path (as illustrated in Figure 3.2) to configure a specific command. The colon at the beginning of each line denotes that all line signals are root. Use a colon (:) to separate levels. Use the semicolon (;) to separate two commands on the same line.

For example, to format the command for the NAME function, use this path:

```
:CALCulate:MATH:EXPRession:NAME
```

To format the NAME and CATalog function, use a single command:

```
:CALCulate:MATH:EXPRession:NAME
```

If the command is a setting, then put the parameter after the instruction. If the command is an inquiry, then put a question mark (?) after the instruction.

For example, to set the frequency to 1kHz:

```
:SOURce:FREQuency 1000
```

To inquire what the frequency is set to:

```
:SOURce:FREQuency?
```

The lowercase letters and portion in parenthesis can be omitted so the above instruction can be rewritten as:

```
:SOUR:FREQ;
```

The Ending Code can be any type in Table 3-5.

Table 3-5: IEEE-488 Interface Ending Codes

Ending Code
[CR] (0Dh)
[LF] (0Ah)
[CR] (0Dh) + [LF] (0Ah)

3.2.5 IEEE-488 Commands - Detailed

The IEEE commands listed in Figure 3-2 are detailed in paragraphs 3.2.5.1 – 3.2.5.51 including command, parameter, return value, function, and description. **Note:** Numerical data is transferred via one of three methods: integer format, fixed decimal format or floating point decimal format. Refer to Figure 3-3.

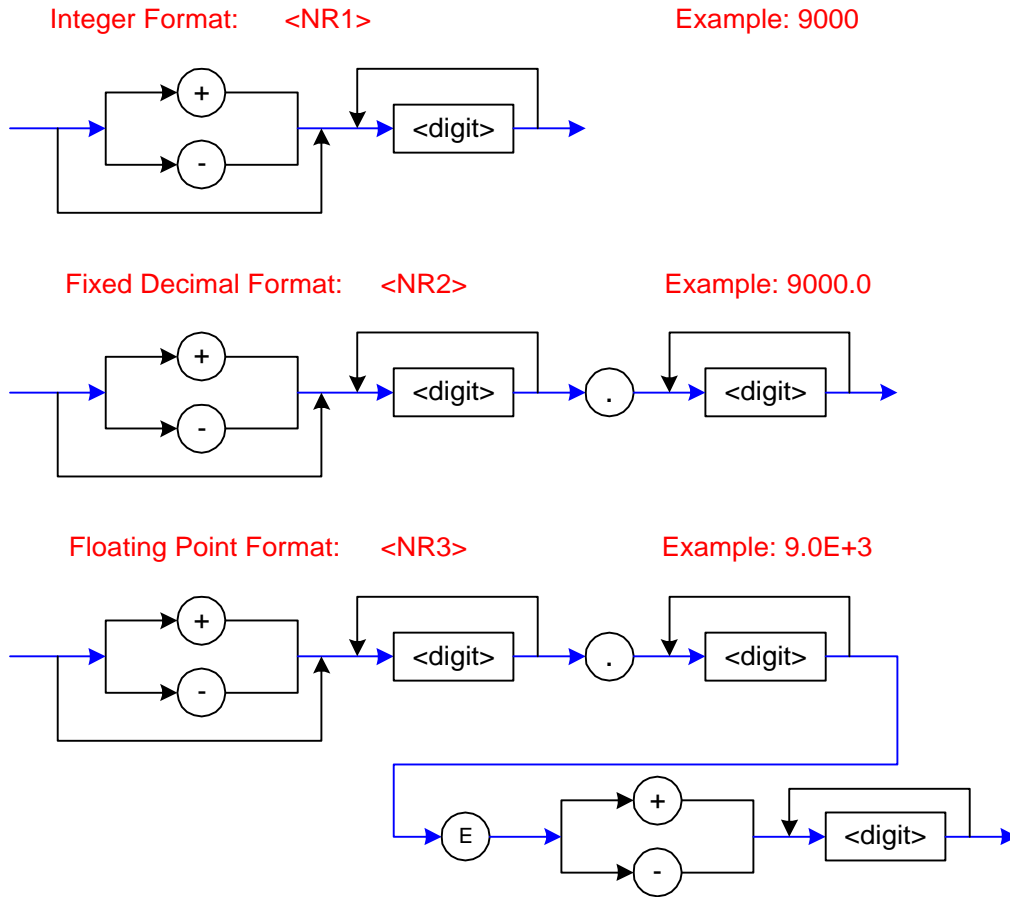

Figure 3-3: Numerical Data Transfer

3.2.5.1 CALCulate1:FORMat

Instruction: CALCulate1:FORMat
Parameter: {REAL | MLINear | CP | CS | LP | LS | ZS | RS | RP}
Return Value: {REAL | MLINear | CP | CS | LP | LS | ZS | RS | RP}
Function: Set or Query the primary measurement parameter.
Description: REAL Impedance, Real
MLINear Impedance, absolute value
CP Equivalent parallel capacitance
CS Equivalent series capacitance
LP Equivalent parallel inductance
LS Equivalent series inductance
ZS Equivalent series impedance
RS Equivalent series resistance
RP Equivalent parallel resistance
Example: :CALC1:FORM Ls 'set primary parameter to "Ls"'

3.2.5.2 CALCulate2:FORMat

Instruction: CALCulate2:FORMat
Parameter: {IMAGinary | PHASe | D | Q | REAL | RS | XS}
Return Value: {IMAGinary | PHASe | D | Q | REAL | RS | XS}
Function: Set or Query the secondary measurement parameter.
Description: IMAGinary Impedance, Imaginary
PHASe Phase angle
D Dissipation factor
Q Quality factor
REAL Impedance, Real
RS Equivalent series resistance
XS Equivalent series reactance (imaginary)
Example: :CALC2:FORM Xs 'set secondary parameter to "Xs"'

3.2.5.3 CALCulate{1 | 2}:LIMit:LOWer[:DATA]

Instruction: CALCulate{1 | 2}:LIMit:LOWer[:DATA]
Parameter: {The lower limit value | MAXimum | MINimum}
Return Value: The lower limit value, the format is <NR3> (Floating point)
Function: Set or query the lower limit value.
Description: MINimum -9.999E14
MAXimum 9.999E14
Example: :CALC1:LIM:LOW 8 'set primary low limit to compare to "8"'

3.2.5.4 CALCulate{1 | 2}:LIMit:STATe

Instruction: CALCulate{1 | 2}:LIMit:STATe
Parameter: {ON (1) | OFF (0)}
Return Value: {1 | 0}
Function: Set or query if the Compare function is ON or OFF.
Description: ON (1) Turn on Compare function
OFF (0) Turn off Compare function
Example: :CALC1:LIM:STATE OFF

3.2.5.5 CALCulate{1 | 2}:LIMit:UPPer[:DATA]

Instruction: CALCulate{1 | 2}:LIMit:UPPer[:DATA]
Parameter: {The upper limit value | MAXimum | MINimum}
Return Value: The upper limit value, the format is <NR3> (Floating point)
Function: Set or query the upper limit value.
Description: MINimum -9.999E14
MAXimum 9.999E14
Example: :CALC2:LIM:UPPER 10 'set upper limit to compare to "10"'

3.2.5.6 CALCulate{1 | 2}:MATH:EXPRession:NAME

Instruction: CALCulate{1 | 2}: MATH:EXPRession:NAME
Parameter: {DEV | PCNT}
Return Value: {DEV | PCNT}
Function: Set the Compare function value to deviation or percent deviation.
Example: :CALC1:MATH:EXPR:NAME PCNT

3.2.5.7 CALCulate{1 | 2}:MATH:STATe

Instruction: CALCulate{1 | 2}:MATH:STATe
Parameter: {ON (1) | OFF (0)}
Return Value: {1 | 0}
Function: Set or query if CALCulate{1 | 2}: MATH:EXPRession:NAME is ON or OFF.
Description: ON (1) Turn on CALCulate{1 | 2}: MATH:EXPRession:NAME
OFF (0) Turn off CALCulate{1 | 2}: MATH:EXPRession:NAME
Example: :CALC1:MATH:STATe ON

3.2.5.8 :DATA[:DATA]

Instruction: :DATA[:DATA]
Parameter: MAXimum MINimum
Return Value: The compare data of primary in <NR3> format (-9.999E14 to 9.999E14)
Function: Query the compare data of the primary parameter.
Example: :DATA 9 'set nominal value for compare to "9"'

3.2.5.9 FETCh?

Instruction: FETCh?
Parameter: None
Return Value: <STATE>, <DAT1>, <DAT2>, <CMP1>, <CMP2>
Function: Get the result from the INITiate or *trg function.
Description: <STATE> Measuring status
0 Normal
1 Overload
2 DUT disconnected
<DAT1> test value of primary parameter
<DAT2> test value of secondary parameter
When the Compare function is enabled, results are:
<CMP1> comparison value of primary parameter
<CMP2> comparison value of secondary parameter
0 No secondary parameter
1 Test value in range
2 Test value too high
4 Test value too low
8 DUT disconnected

When the BINNING function is enabled, results are:
<BIN> The sorting result
0 Secondary parameter FAILED
1 ~ 8 Primary Parameter and Secondary Parameter PASSED
9 Primary Parameter FAILED
Example: :FETCh?
Response: 0, 6.623456E-06, 2.293633E+00

3.2.5.10 [:SENSe]:CORRection:COLLEct[:ACQuire]:STANdard

Instruction: [:SENSe]:CORR:COLL[:ACQ]:STAN
Parameter: {1|2}
Return Value: None
Function: Execute the OPEN or SHORT correction.
Description: 1 Execute the OPEN correction
2 Execute the SHORT correction
Example: :SENS:CORR:COLL:ACQ STAN1
:SENS:CORR:COLL:ACQ STAN2

3.2.5.11 [:SENSe]:CORRection:DATA?STANdard

Instruction: [:SENSe]:CORR:DATA?STAN
Parameter: {1|2}
Return Value: Two correction values in <NR3> format
Function: Queries the OPEN or SHORT correction value.
Description: 1 Query the OPEN correction value (G and B)
2 Query the SHORT correction value (R and X)
Example: :SENS:CORR:DATA? STAN1
:SENS:CORR:DATA? STAN2

3.2.5.12 [:SENSe]:FIMPedance:APERature

Instruction: [:SENSe]:FIMPedance:APERature
Parameter: 0.025 (Fast), 0.065 (Medium), 0.500 (Slow)
Return Value: 0.025 (Fast), 0.065 (Medium), 0.500 (Slow)
Function: Set or query the measurement speed.
Example: :SENSe:FIMP:APER SLOW

3.2.5.13 [:SENSe]:FIMPedance:RANGe:AUTO

Instruction: [:SENSe]:FIMPedance:RANGe:AUTO
Parameter: {ON (1)|OFF (0)}
Return Value: {1|0}
Function: Set or query if the Auto Range is ON or OFF.
Description: ON (1) Turn on Auto Range
OFF (0) Turn off Auto Range
Example: :SENSe:FIMP:RANGe:AUTO ON

3.2.5.14 [:SENSe]:FIMPedance:RANGe[:UPPer]

Instruction: [:SENSe]:FIMPedance:RANGe[:UPPer]
Parameter: {Measured value range | UP | DOWN}
Unit: [MOHM | KOHM | OHM | mOHM], default is OHM
Return Value: {Measured value range} in <NR3> format
Function: Set or query which Measurement Range is enabled.
Range Values: 100000, 10000, 1000, 100 and 10.
Example: :SENSe:FIMP:RANGe 1000

3.2.5.15 SOURce:FREQuency[:CW]

Instruction: SOURce:FREQuency[:CW]
Parameter: Test Frequency
Unit: [Hz | kHz], default is Hz
Return Value: {Test Frequency} in <NR3> format
Function: Set or query the test frequency.
Range Values: 100Hz, 120Hz, 1kHz and 10kHz
Example: :SOURce:FREQ 10000

3.2.5.16 SOURce:VOLTage[:LEVel][:IMMEDIATE][AMPLitude]

Instruction: SOURce:VOLTage[:LEVel][:IMMEDIATE][AMPLitude]
Parameter: Test Voltage
Return Value: {Test Voltage} in <NR3> format
Function: Set or query the test voltage.
Range Values: 0.25 and 1.0V
Example: :SOURce:VOLT 1.0

3.2.5.17 SYSTem:BEEPer:STATe

Instruction: SYSTem:BEEPer:STATe
Parameter: {OFF (0) | ON, LOW (1) | ON, HIGH (2)}
Return Value: {0 | 1 | 2}
Function: Set the loudness of the beeper.
Example: :SYSTem:BEEPer:STATe 1 'set beeper to "low"'

3.2.5.18 SYSTem:ERRor?

Instruction: SYSTem:ERRor?
Parameter: None
Return Value: Error message
Function: Query if there are any system errors.
Example: :SYSTem:ERRor?
Response: "0, "No Error""

3.2.5.19 SYSTem:KLOCK

Instruction: SYSTem:KLOCK
Parameter: {ON (1) | OFF (0)}
Return Value: {1 | 0}
Function: Set or query if the Key Lock function is ON or OFF.
Description: ON (1) Turn on Key Lock
OFF (0) Turn off Key Lock
Example: :SYSTem:KLOCK 0 'set key lock "Off"'

3.2.5.20 SYSTem:LFRequency

Instruction: SYSTem:LFRequency
Parameter: {50 | 60}
Return Value: {50 | 60}
Function: Set or query if the Line Frequency.
Example: :SYSTem:LFRequency 50

3.2.5.21 SYSTem:PRESet

Instruction: SYSTem:PRESet
Parameter: None
Return Value: None
Function: Set the instrument to initial default values.
Example: :SYSTem:PRESet

3.2.5.22 SYSTem:HANDler

Instruction: SYSTem:HANDler
Parameter: {CLEAr | HOLD}
Return Value: {CLEAr | HOLD}
Function: Set the Handler to clear result or hold result for each test.
Example: :SYSTem:HANDler CLEAr

3.2.5.23 SYSTem:ALARm

Instruction: SYSTem:ALARm
Parameter: {PULSe | CONTInuous}
Return Value: {PULSe | CONTInuous}
Function: Set the mode the alarm will sound in.
Example: :SYSTem:ALARm PULSe

3.2.5.24 TRIGger:DELay

Instruction: TRIGger:DELay
Parameter: Trigger Delay Time
Unit: [MS | S], default is S
Return Value: {Trigger Delay Time} in <NR3> format
Function: Set or query the trigger delay time.
Range Values: 0 ~ 9999ms
Example: :TRIGger:DELay .500 'set trigger delay to "500ms"'

3.2.5.25 TRIGger:SOURce

Instruction: TRIGger:SOURce
Parameter: {BUS | EXTernal | MANual}
Return Value: {BUS | EXTernal | MANual}
Function: Set or query the trigger mode.
Description: BUS Bus trigger
EXTernal External trigger
MANual Manual trigger
Example: :TRIGger:SOURce MANual

3.2.5.26 TRIGger:EDGE

Instruction: TRIGger:EDGE
Parameter: {FALLing | RISIng1}
Return Value: {FALL | RISI}
Function: Set or query the trigger edge.
Example: :TRIGger:EDGE FALLing

3.2.5.27 BINNing:UPPer:BIN{1~8}

Instruction: BINNing:UPPer:BIN{1~8}
Parameter: {? | , <number> (NR3 mode)}
Return Value: {The high limit of each BIN}
Function: Set the high limit of each bin within the value +999.99 to -999.99%.
To set BIN2 to +99.89%, send the command BINNing:UPPer:BIN2,+99.89
and send command BINNing:UPPer:BIN2? for query.
Example: :BINNing:BIN1 10 'set upper limit for Bin 1 to "10%"'

3.2.5.28 BINNING:UPPER:AUX

Instruction: BINNING:UPPER:AUX
Parameter: {The high limit of the secondary parameter (NR3 mode)}
Return Value: {The high limit of the secondary parameter}
Function: Set the AUX HI limit for BINNING of secondary parameter.
Example: :BINNING:UPPER:AUX 10 'set secondary high limit to "10"'

3.2.5.29 BINNING:LOWER:BIN{1~8}

Instruction: BINNING:LOWER:BIN{1~8}
Parameter: {? | , <number> (NR3 mode)}
Return Value: {The low limit of each BIN}
Function: Set the low limit of each bin.
Example: :BINNING:LOWER:BIN2 8 'set lower limit for Bin 2 to "8"'

3.2.5.30 BINNING:LOWER:AUX

Instruction: BINNING:LOWER:AUX
Parameter: {The low limit of the secondary parameter (NR3 mode)}
Return Value: {The low limit of the secondary parameter}
Function: Set the AUX LO limit for BINNING of secondary parameter.
Example: :BINNING:LOWER:AUX 8 'set secondary low limit to "8"'

3.2.5.31 BINNING:NOMINAL

Instruction: BINNING:NOMINAL
Parameter: {The nominal of the primary parameter (NR3 mode)}
Return Value: {The nominal of the primary parameter}
Function: Set the NOMINAL limit for BINNING of primary parameter.
Example: :BINNING:NOMINAL 100 'set nominal value to "100"'

3.2.5.32 BINNING:STATE

Instruction: BINNING:STATE
Parameter: {ON (1) | OFF (0)}
Return Value: {1 | 0}
Function: Set the BINNING function ON or OFF.
Example: :BINNING:STATE ON

3.2.6 Binning Example

Here is an example to program the bin limits for a binning operation. In this example Bin1 has a high/low limit of $\pm 1.2\%$. Bin2 has a high/low limit of $\pm 2.2\%$. Both nested around the nominal value of $100\text{m}\Omega$.

:BINning:NOMInal 100e3;	Sets the nominal value to 100m
:BINning:UPPer:AUX 1;	Sets the AUX-HI limit value to 1
:BINning:LOWer:AUX 0;	Sets the AUX_LO limit value to 0
:BINning:UPPer:BIN1,+1.2;	Sets the Bin1 HI limit value to +1.2%
:BINning:LOWer:BIN1,-1.2;	Sets the Bin1 LO limit value to -1.2%
:BINning:UPPer:BIN2,+2.2;	Sets the Bin2 HI limit value to +2.2%
:BINning:LOWer:BIN2,-2.2;	Sets the Bin2 LO limit value to -2.2%
:BINning:STATe ON;	Enables Binning function
:BINning:RESUlt?	Query the Binning result

3.2.7 Compare Example

Here is an example to program the nominal, high and low limits for a compare operation. In this example the 1715 instrument is programmed with the primary parameter Rs and the secondary parameter Q at 1kHz and 1V. The auto range is OFF and the 100Ω Range is selected. The primary nominal value is set to 24.9Ω, the primary low limit is set to 20Ω and the primary high limit is set to 30Ω. The Compare display selected is “ON-VAL”. **Note:** the Compare function is turned on **after** the limits are set.

```
NI = 0
datakeep$ = "no"
passall$ = "yes"
If NI = 1 Then
Open "gpib0" For Output As #1
Open "gpib0" For Input As #2
Print #1, "ABORT"
Print #1, "RESET"
Print #1, "gpibeos lf"
Else
Open "\dev\ieeeeout" For Output As #1
IOCTL #1, "BREAK"
Print #1, "RESET"
Open "\dev\ieeeein" For Input As #2
Print #1, "TERM LF"
End If
K2 = 1000
fr = 100000
cmdl$ = "C"

Print #1, "output 17; TRIG:SOUR ext"
For G = 1 To k2: Next G
Print #1, "output 17; :SOUR:FREQ "; 1000
For G = 1 To k2: Next G
Print #1, "output 17; :SENS:FIMP:APER SLOW"
For G = 1 To k2: Next G
Print #1, "output 17; :SOUR:VOLT 1.0"
For G = 1 To k2: Next G
Print #1, "output 17; :CALC2:FORM Q"
For G = 1 To k2: Next G
Print #1, "output 17; :CALC1:FORM RS"
For G = 1 To k2: Next G
Rem now for bin limits
Print #1, "output 17; :data 24.9;"
For G = 1 To k2: Next G
Print #1, "output 17; :sens:fimp:rang:auto off"
For G = 1 To k2: Next G
Print #1, "output 17; :sens:fimp:rang 100"
For G = 1 To k2: Next G
Print #1, "output 17; :CALC1:lim:lower 20"
For G = 1 To k2: Next G
Print #1, "output 17; :CALC1:lim:upper 30"
For G = 1 To k2: Next G
Print #1, "output 17; :CALC1:lim:state on"
For G = 1 To k2: Next G
Print #1, "output 17; :CALC1:math:state on"
For G = 1 To k2: Next G
Print #1, "output 17; :CALC1:math:expr:name:dev"
For G = 1 To k2: Next G
```

3.2.8 Sample IEEE-488 Basic Program

Included herein is a sample Basic program.

NOTE:

Refer to: <http://www.quadtech.com> for the latest sample programs that may be available.

```
NI = 0
IF NI = 1 THEN
OPEN "gpib0" FOR OUTPUT AS #1
OPEN "gpib0" FOR INPUT AS #2
PRINT #1, "ABORT"
PRINT #1, "RESET"
PRINT #1, "gpibeos lf"
ELSE
OPEN "\dev\ieeeeout" FOR OUTPUT AS #1
IOCTL #1, "BREAK"
PRINT #1, "RESET"
OPEN "\dev\ieeeein" FOR INPUT AS #2
PRINT #1, "TERM LF"
END IF

k2 = 1000
fr = 100000
Cmdl$ = "C"

Print "Configuring the 1715"

PRINT #1, "output 17; TRIG:SOUR MAN"
FOR g = 1 TO k2: NEXT g
PRINT #1, "output 17; :SOUR:FREQ "; fr
FOR g = 1 TO k2: NEXT g
PRINT #1, "output 17; :SENS:FIMP:APER SLOW"
FOR g = 1 TO k2: NEXT g
PRINT #1, "output 17; :SOUR:VOLT 1.0"
FOR g = 1 TO k2: NEXT g
PRINT #1, "output 17; :FIMP:RANG:AUTO ON"
FOR g = 1 TO k2: NEXT g
PRINT #1, "output 17; :CALC1:FORM REAL"
FOR g = 1 TO k2: NEXT g
PRINT #1, "output 17; :CALC2:FORM IMAG"
FOR g = 1 TO k2: NEXT g

IF cmdl$ = "C" THEN
PRINT #1, "output 17; :CALC2:FORM D"
PRINT #1, "output 17; :CALC1:FORM CP"
ELSEIF cmdl$ = "R" THEN
PRINT #1, "output 17; :CALC2:FORM Q"
PRINT #1, "output 17; :CALC1:FORM RS"
ELSEIF cmdl$ = "L" THEN
PRINT #1, "output 17; :CALC1:FORM LS"
PRINT #1, "output 17; :CALC2:FORM Q"
END IF

PRINT #1, "output 17;*TRG"
FOR g = 1 TO k2: NEXT g
PRINT #1, "output 17;fetch?"
PRINT #1, "enter 17"
REM get and parse return data

INPUT #2, s1$
INPUT #2, f3$
INPUT #2, f6$

PRINT "Data is:",s1$,f3$,f6$
```

3.3 Handler Interface

A Handler interface (Figure 3-4) is an available option for the 1715 instrument. Connection is made through the blue 24-pin connector labeled “HANDLER” on the rear panel of the 1715 instrument. Figure 3-5 illustrates a simple START switch using the Handler interface.

1715 HANDLER Interface PIN Configuration: Rear Panel View

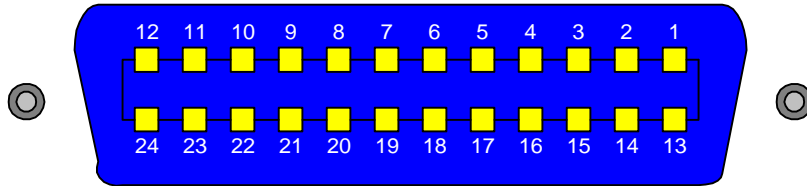

1715 HANDLER Interface
PIN Designation
BINNING

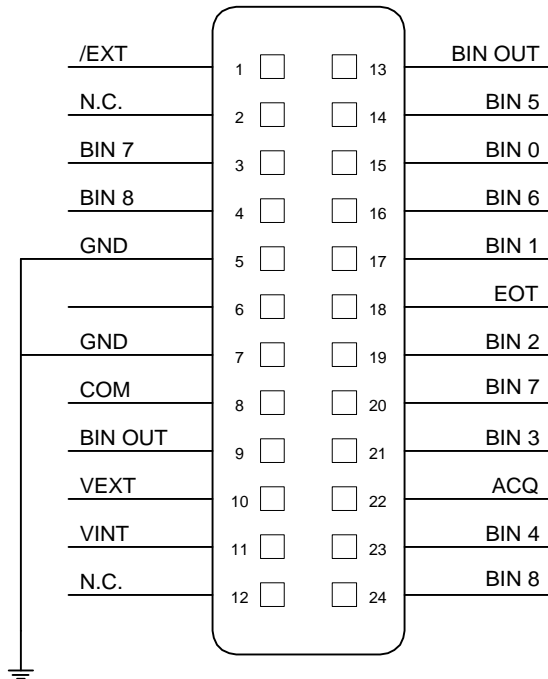

1715 HANDLER Interface
PIN Designation
COMPARE

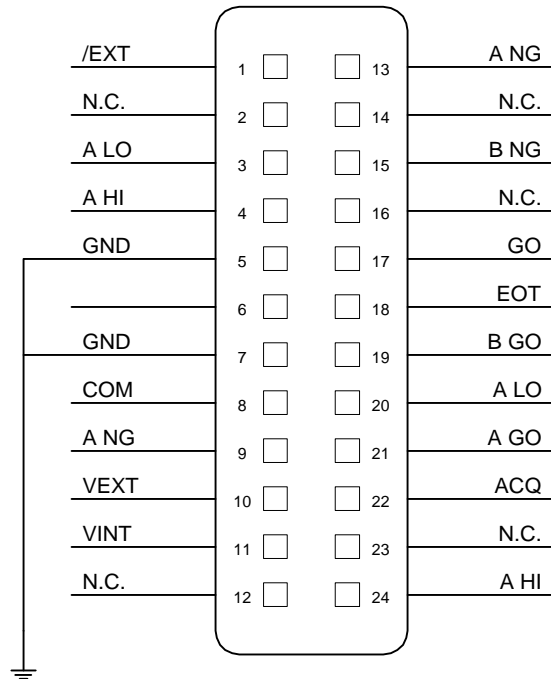

Figure 3-4: Handler Interface Pin Configuration

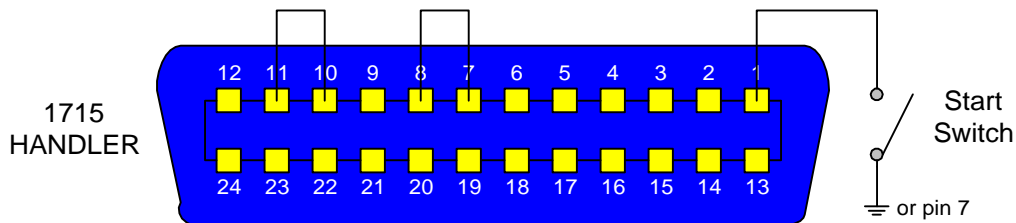

Figure 3-5: Simple Start Switch

Paragraph 2.3.4.5 contains the instructions for changing the Handler mode. Paragraphs 2.3.4.7 and 2.3.4.8 contain instructions for setting the Trigger Delay time and selecting the Trigger Edge. Figure 3-6 illustrates the Trigger function.

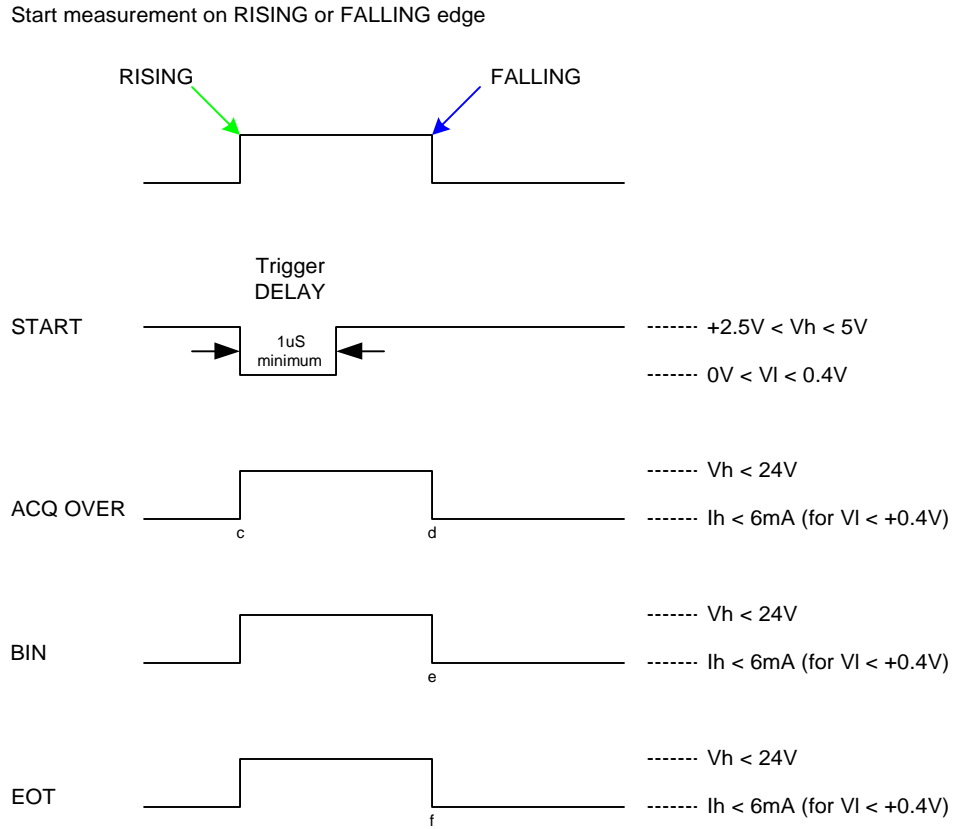

Figure 3-6: Trigger

Output Signals

The output lines of the 1715 Handler interface are open collector drivers that pull each signal line to a low voltage, signal ground when the signal is active (true). Each external line should be pulled up (with a resistor) to a positive voltage between 5V and 24V. The pull-up resistor must limit the current to $< 6mA$ for a signal of a comparison function and to $< 5mA$ for a control signal (EOT).

Input Signal

The input signal to the 1715 Handler interface is active low and requires a positive external voltage to pull the signal down below 0.4V, ground.

3.3.1 Handler Pin Assignments for Binning Operation

Table 3-6 lists the pin assignments when the handler interface on the 1715 instrument is performing a Binning operation. The device under test is sorted by test value. The test limits can be set as absolute value or percent value.

Table 3-6: Handler Pin Assignments for Binning

Pin	Name	Description
1	/EXT	External trigger
2	X	No connection
3, 20	BIN 7	Primary parameter pass (within Bin 7 limits)
4, 24	BIN 8	Primary parameter pass (within Bin 8 limits)
5 - 7	GND	Chassis Ground
8	COM	Common Ground
9, 13	BIN OUT	Primary parameter fail
10	VEXT	External DC voltage: 5V ~ 24V
11	VINT	Internal DC voltage: +5V
12	N.C.	No Connection
14	BIN 5	Primary parameter pass (within Bin 5 limits)
15	BIN 0	Secondary parameter fail
16	BIN 6	Primary parameter pass (within Bin 6 limits)
17	BIN 1	Primary parameter pass (within Bin 1 limits)
18	EOT	End of Test
19	BIN 2	Primary parameter pass (within Bin 2 limits)
21	BIN 3	Primary parameter pass (within Bin 3 limits)
22	ACQ	Received data, ready to accept next
23	BIN 4	Primary parameter pass (within Bin 4 limits)

Compatibility with 1658-9620 & 1658-9630
 (Handler Interface for the 1689, 92, 93 & 59 Digibridges):
 Short pins 7 & 8 together and short pins 10 & 11 together to make the Handler compatible.

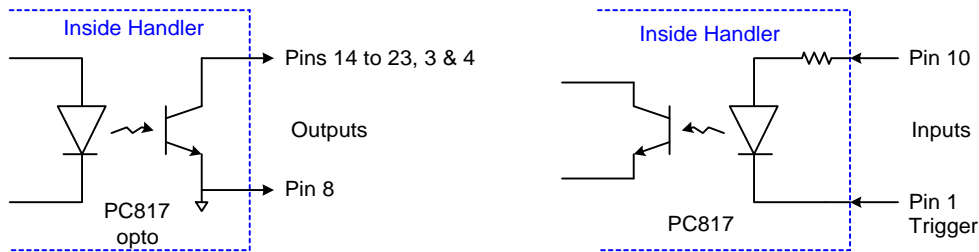

Figure 3-7: Handler I/O Pins

NOTE:
 When using external DC voltage (VEXT), pins 5, 6 & 7 (GND) must be connected to pin 8 (COM).

3.3.2 Handler Pin Assignments for Compare Operation

Table 3-7 lists the pin assignments when the handler interface on the 1715 instrument is performing a Compare operation. The device under test is being compared against a standard of known value. High and low limits can be defined as absolute value or percent value.

Table 3-7: Handler Pin Assignments for Compare

Pin	Name	Description
1	/EXT	External Trigger
2	X	No connection
3, 20	A LO	Primary parameter fail low (test value below low limit)
4, 24	A HI	Primary parameter fail high (test value above high limit)
5 - 7	GND	Chassis Ground
8	COM	Common Ground
9, 13	A NG	Primary parameter fail (No Good)
10	VEXT	External DC voltage: 5V ~ 24V
11	VINT	Internal DC voltage: +5V
12	X	No connection
14	X	No connection
15	B NG	Secondary parameter fail (No Good)
16	X	No connection
17	GO	Primary and Secondary parameters pass
18	EOT	End of Test
19	B GO	Secondary parameter pass (test value within limits)
21	A GO	Primary parameter pass (test value within limits)
22	ACQ	Received data, ready to accept next
23	X	No connection

NOTE:

When using external DC voltage (VEXT), pins 5, 6 & 7 (GND) must be connected to pin 8 (COM).

Section 4: Service & Calibration

4.1 General

Our warranty (at the front of this manual) attests to the quality of materials and workmanship in our products. If malfunction should be suspected or other information be desired, applications engineers are available for technical assistance. Application assistance is available in the U.S. by calling 800-253-1230 and asking for Applications Support. For support outside of the United States, please contact your local [QuadTech Distributor](#).

4.2 Instrument Return

Before returning an instrument to QuadTech for [Service](#) please obtain an [online Return Materials Authorization Number \(RMA#\)](#). This number, when placed on the outside of the shipping package, will speed processing at our Service Lab and will serve as a reference number for the time your unit is at QuadTech. Please contact our **Customer Care Center (CCC)** at **800-253-1230** for additional support. The CCC phone line is staffed from 8:00am to 5:00pm (EST).

It will be necessary to include a Purchase Order Number and credit card information to insure expedient processing, although units found to be in warranty will be repaired at no-charge. For any questions on repair costs or shipment instructions please contact our CCC Department at the above number. To safeguard an instrument during storage and shipping please use packaging that is adequate to protect it from damage, i.e., equivalent to the original packaging and mark the box "Delicate Electronic Instrument". Please follow online instructions for shipping materials back to QuadTech.

4.3 Calibration

Calibration of the 1715 LCR Digibridge instruments is completed at the factory and includes a NIST calibration certificate. Verification of instrument operation and accuracy is recommended on an annual basis. Accurate operation of the 1715 instrument is confirmed using the 1715-TP Verification Procedure.

4.3.1 1715 Verification Procedure

This section outlines the relevant information to verify performance of the 1715 LCR Meter. It is recommended that performance be performed at least once a year using this outline procedure. Instrument should be warmed up for a minimum of 15 minutes prior to verification. Verification should be performed under the following conditions: Temperature equal to $23^{\circ}\text{C} \pm 1.2^{\circ}\text{C}$ and Relative Humidity (RH) between 35% and 55%.

Recommended standards are listed below. All standards should be traceable to a National Laboratory such as N.I.S.T. with calibrated values for primary and secondary parameters at the required test frequencies. QuadTech's verification conforms to ANSI Z540 and QuadTech recommends that the calibrated values for the primary and secondary standards have an uncertainty 4 times better than the primary and secondary accuracy specified in the Verification Data Sheet. If the calibrated values for the standards used do not have an uncertainty of 4 times better than the specified accuracy of the 1715 the uncertainty of the standard should be added to the specified accuracy of the 1715. For example: if the calibrated value of the $500\text{m}\Omega$ standard is $495.0\text{m}\Omega \pm 1\%$ at 100Hz, the expected reading on the 1715 would be $495.0\text{ m}\Omega \pm 1.7\%$ (1% for the standard accuracy plus 0.7% for the 1715 accuracy). This also applies for secondary parameters as well.

Primary and secondary accuracy specifications given in the Verification Data Sheet are based upon the accuracy formulas in section 2.4.5 of this manual.

Measurement Standards

Inductance Standards 4 Terminal

Inductor	10 μH (nominal value)
Inductor	100 μH (nominal value)
Inductor	1000 μH (nominal value)

Standard Open and Short

Resistance Standards 4 Terminal

Resistor	95K ohm (nominal value)
Resistor	6K ohm (nominal value)
Resistor	374 ohm (nominal value)
Resistor	25 ohm (nominal value)
Resistor	5 ohm (nominal value)
Resistor	500m ohm (nominal value)

Capacitance Standards 2 or 4 Terminal

Capacitor	50pF (nominal value)
Capacitor	100pF (nominal value)
Capacitor	200pF (nominal value)
Capacitor	500pF (nominal value)
Capacitor	1000pF (nominal value)
Capacitor	0.1 μF (nominal value)
Capacitor	0.05 μF (nominal value)
Capacitor	0.02 μF (nominal value)
Capacitor	0.01 μF (nominal value)
Capacitor	0.002 μF (nominal value)

Measurement Procedure

The 1715 should be set to the following:

[MEAS DISPLAY]

Range: = Auto
 Level: 1Volt
 Speed: = Slow
 Trigger = Manual
 Binning = Off
 Compare = Off

Connections to all standards should be via a 1-meter cable.

A multiple frequency open and short correct should be performed prior to any measurements. See paragraph 2.5.5 for information on performing an open and short correction.

Connect each standard listed in the Verification Data Sheet and select the test frequency in the [MEAS DISPLAY] menu of the 1715. Record the results in the Verification Data Sheet.

4.3.2 1715 Verification Data Sheet

R500m DC uncertainty +/- 50ppm								
Freq	Primary	Secondary	Voltage	Pmax	SMax	Pspec	Sspec	
100	0.49999824	0.000004	1			1.00%	0.0100	PASS
120	0.49999824	0.000005	1			0.80%	0.0080	PASS
1000	0.49999824	0.000039	1			0.80%	0.0080	PASS
10000	0.49999824	0.000389	1			1.20%	0.0120	PASS
R5 DC uncertainty +/- 50ppm								
Freq	Primary	Secondary	Voltage	Pmax	SMax	Pspec	Sspec	
100	4.99569941	0.000001	1			0.40%	0.0040	PASS
120	4.99569941	0.000001	1			0.30%	0.0030	PASS
1000	4.99569941	0.000009	1			0.25%	0.0025	PASS
10000	4.99569941	0.000085	1			0.30%	0.0030	PASS
R25 DC uncertainty +/- 50ppm								
Freq	Primary	Secondary	Voltage	Pmax	SMax	Pspec	Sspec	
100	24.9000072	0.000000	1			0.30%	0.0030	PASS
120	24.9000072	0.000000	1			0.25%	0.0025	PASS
1000	24.9000072	0.000003	1			0.20%	0.0020	PASS
10000	24.9000072	0.000027	1			0.20%	0.0020	PASS
R374 DC uncertainty +/- 50ppm								
Freq	Primary	Secondary	Voltage	Pmax	SMax	Pspec	Sspec	
100	373.969269	0.000000	1			0.20%	0.0020	PASS
120	373.969269	0.000000	1			0.20%	0.0020	PASS
1000	373.969269	0.000000	1			0.20%	0.0020	PASS
10000	373.969269	-0.000001	1			0.20%	0.0020	PASS

R6K		DC uncertainty +/- 50ppm							
Freq	Primary	Secondary	Voltage	Pmax	SMax	Pspec	Sspec		
100	5968.78174	-0.000003	1			0.20%	0.0020	PASS	
120	5968.78174	-0.000003	1			0.20%	0.0020	PASS	
1000	5968.78174	-0.000029	1			0.20%	0.0020	PASS	
10000	5968.78125	-0.000286	1			0.20%	0.0020	PASS	
R95.3K		DC uncertainty +/- 50ppm							
Freq	Primary	Secondary	Voltage	Pmax	SMax	Pspec	Sspec		
100	95299.547	-0.000034	1			0.40%	0.0040	PASS	
120	95299.547	-0.000041	1			0.30%	0.0030	PASS	
1000	95299.539	-0.000343	1			0.20%	0.0020	PASS	
10000	95298.422	-0.003433	1			0.60%	0.0061	PASS	
C50pF		uncertainty at 1kHz primary +/- 0.025%, secondary +/- 0.02							
Freq	Primary	Secondary	Voltage	Pmax	SMax	Pspec	Sspec		
1000	4.980E-11	0.000082	1			0.80%	0.0091	PASS	
10000	4.980E-11	0.000053	1			0.90%	0.0130	PASS	
C100pF		uncertainty at 1kHz primary +/- 0.025%, secondary +/- 0.02							
Freq	Primary	Secondary	Voltage	Pmax	SMax	Pspec	Sspec		
1000	9.990E-11	0.000046	1			0.80%	0.0091	PASS	
10000	9.990E-11	0.000032	1			0.90%	0.013	PASS	
C200pF		uncertainty at 1kHz primary +/- 0.025%, secondary +/- 0.05							
Freq	Primary	Secondary	Voltage	Pmax	SMax	Pspec	Sspec		
100	1.995E-10	0.000100	1			2.50%	0.0261	PASS	
120	1.995E-10	0.000087	1			1.00%	0.0105	PASS	
1000	1.995E-10	0.000028	1			0.40%	0.0046	PASS	
10000	1.995E-10	0.000021	1			0.60%	0.0087	PASS	
C500pF		uncertainty at 1kHz primary +/- 0.01%, secondary +/- 100ppm							
Freq	Primary	Secondary	Voltage	Pmax	SMax	Pspec	Sspec		
100	4.9970E-10	0.000037	1			2.50%	0.0261	PASS	
120	4.9970E-10	0.000032	1			1.00%	0.0105	PASS	
1000	4.9970E-10	0.000008	1			0.40%	0.0046	PASS	
10000	4.9970E-10	0.000006	1			0.60%	0.0087	PASS	
C2nF		uncertainty at 1kHz primary +/- 0.01%, secondary +/- 100ppm							
Freq	Primary	Secondary	Voltage	Pmax	SMax	Pspec	Sspec		
100	1.9993E-09	0.000285	1			0.60%	0.0063	PASS	
120	1.9993E-09	0.000241	1			0.50%	0.0053	PASS	
1000	1.9993E-09	0.000047	1			0.20%	0.0023	PASS	
10000	1.9993E-09	0.000023	1			0.20%	0.0029	PASS	

C10nF uncertainty at 1kHz primary +/- 0.01%, secondary +/- 100ppm								
Freq	Primary	Secondary	Voltage	Pmax	SMax	Pspec	Sspec	
100	1.0001E-08	0.000073	1			0.60%	0.0063	PASS
120	1.0001E-08	0.000064	1			0.50%	0.0052	PASS
1000	1.0001E-08	0.000026	1			0.20%	0.0023	PASS
10000	1.0001E-08	0.000024	1			0.20%	0.0029	PASS
C20nF uncertainty at 1kHz primary +/- 0.01%, secondary +/- 100ppm								
Freq	Primary	Secondary	Voltage	Pmax	SMax	Pspec	Sspec	
100	2.0004E-08	0.000047	1			0.40%	0.0042	PASS
120	2.0004E-08	0.000042	1			0.30%	0.0031	PASS
1000	2.0004E-08	0.000023	1			0.20%	0.0023	PASS
10000	2.0004E-08	0.000027	1			0.20%	0.0029	PASS
C50nF uncertainty at 1kHz primary +/- 0.01%, secondary +/- 100ppm								
Freq	Primary	Secondary	Voltage	Pmax	SMax	Pspec	Sspec	
100	5.0004E-08	0.000031	1			0.40%	0.0042	PASS
120	5.0004E-08	0.000029	1			0.30%	0.0031	PASS
1000	5.0004E-08	0.000023	1			0.20%	0.0023	PASS
10000	5.0004E-08	0.000036	1			0.20%	0.0029	PASS
C100nF uncertainty at 1kHz primary +/- 0.01%, secondary +/- 100ppm								
Freq	Primary	Secondary	Voltage	Pmax	SMax	Pspec	Sspec	
100	1.0001E-07	0.000026	1			0.40%	0.0042	PASS
120	1.0001E-07	0.000025	1			0.30%	0.0031	PASS
1000	1.0001E-07	0.000024	1			0.20%	0.0023	PASS
10000	1.0001E-07	0.000051	1			0.20%	0.0029	PASS
L10uH uncertainty at 1kHz primary +/- 0.01%, secondary +/- 100ppm								
Freq	Primary	Secondary	Voltage	Pmax	SMax	Pspec	Sspec	
10000	9.9996E-06	52.619293	1			1.20%	34.22	PASS
L100uH uncertainty at 1kHz primary +/- 0.01%, secondary +/- 100ppm								
Freq	Primary	Secondary	Voltage	Pmax	SMax	Pspec	Sspec	
1000	1.0027E-04	2.4351	1			1.13%	0.1240	PASS
10000	1.0027E-04	24.2989	1			0.30%	2.3426	PASS
L1000uH uncertainty at 1kHz primary +/- 0.01%, secondary +/- 100ppm								
Freq	Primary	Secondary	Voltage	Pmax	SMax	Pspec	Sspec	
100	9.9933E-04	0.7682	1			2.30%	0.0390	PASS
120	9.9933E-04	0.9218	1			1.67%	0.0406	PASS
1000	9.9933E-04	7.6794	1			0.28%	0.3228	PASS
10000	9.9943E-04	74.2633	1			0.20%	12.67	PASS